

ISTRUZIONI DI POSA

ASSEMBLY INSTRUCTIONS

INSTRUCTIONS DE MONTAGE

MONTAGEANLEITUNG

INSTRUCCIONES PARA LA COLOCACION

CALCOLO DELL'ALZATA (A) / CALCULATION OF THE RISE (A) / CÁLCULO DE LA CONTRAHUELLA (A) / CALCUL DE LA CONTREMARCHE (A) / BERECHNUNG DER STEIGUNG (A)

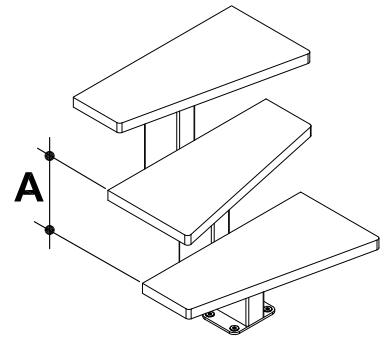
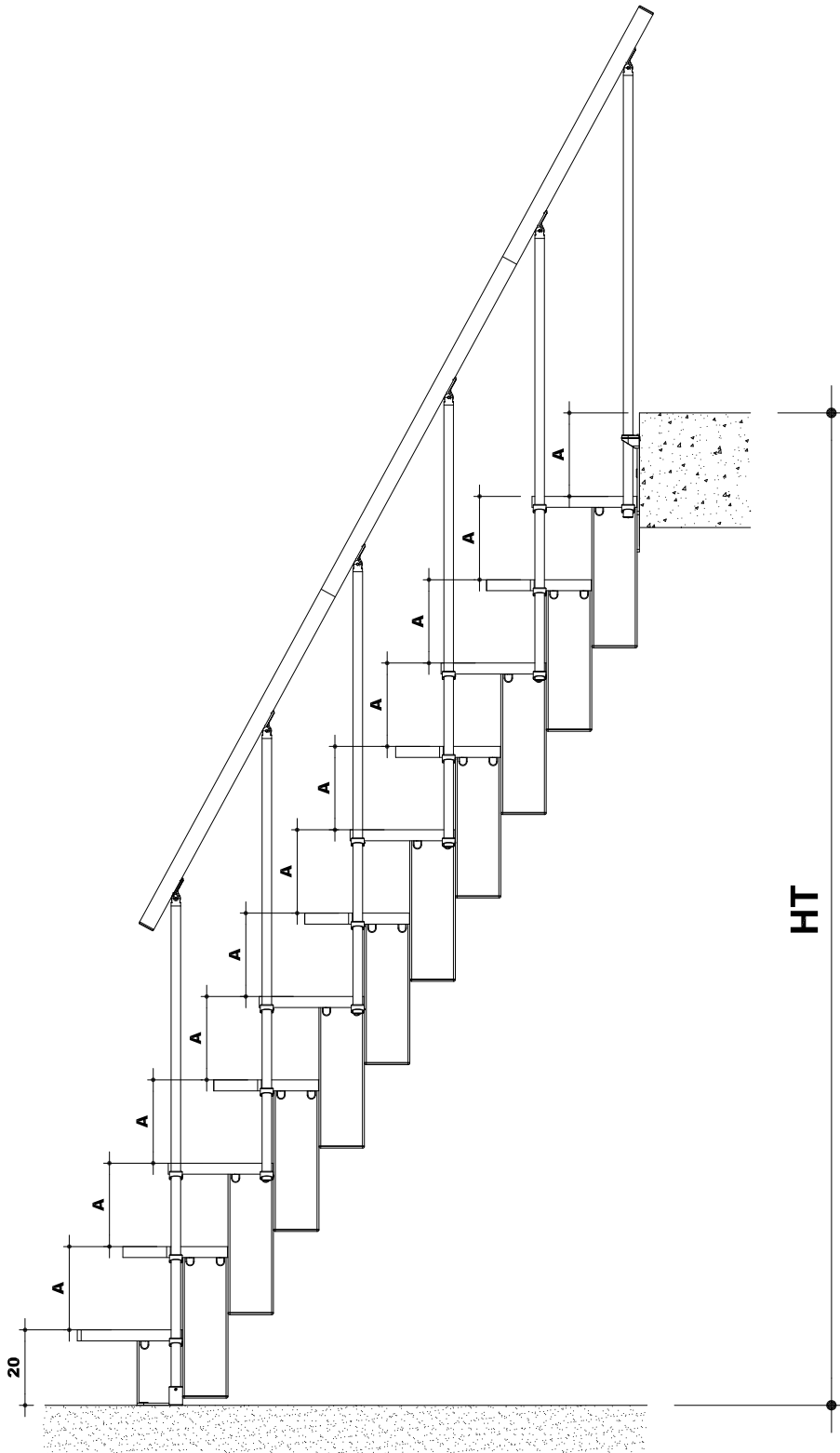

$$20 \leq A \leq 24$$

$$A = (HT - 20) : n$$

- n = numero di gradini
- n = number of steps
- n = número de peldaños
- n = nombre de marches
- n = Anzahl Stufen

HT

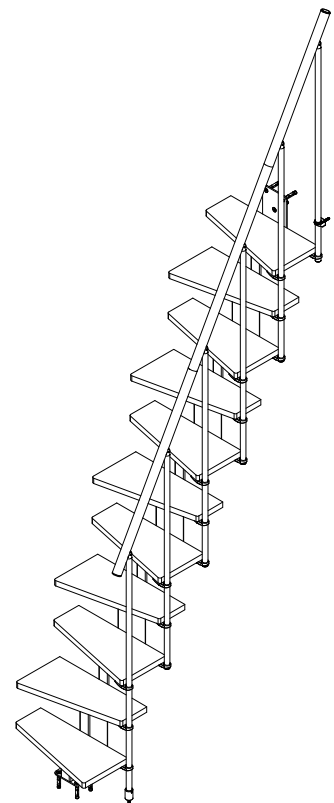
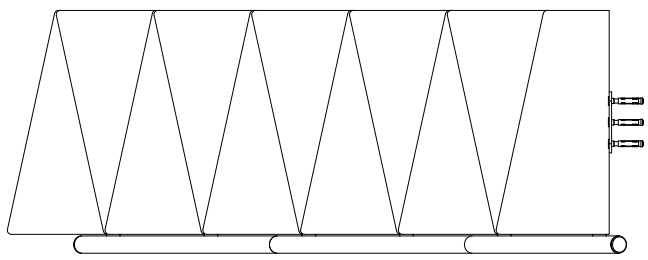

VERIFICA MISURE DEL VANO / VERIFY THE MEASURES OF THE SPACE / COMPROBAR LA MEDIDA DEL ESPACIO /
 VÉRIFIER LES DIMENSIONS DE LA TRÉMIE / ÜBERPRÜFEN SIE DIE ABMESSUNGEN DES TREPPENAUGES

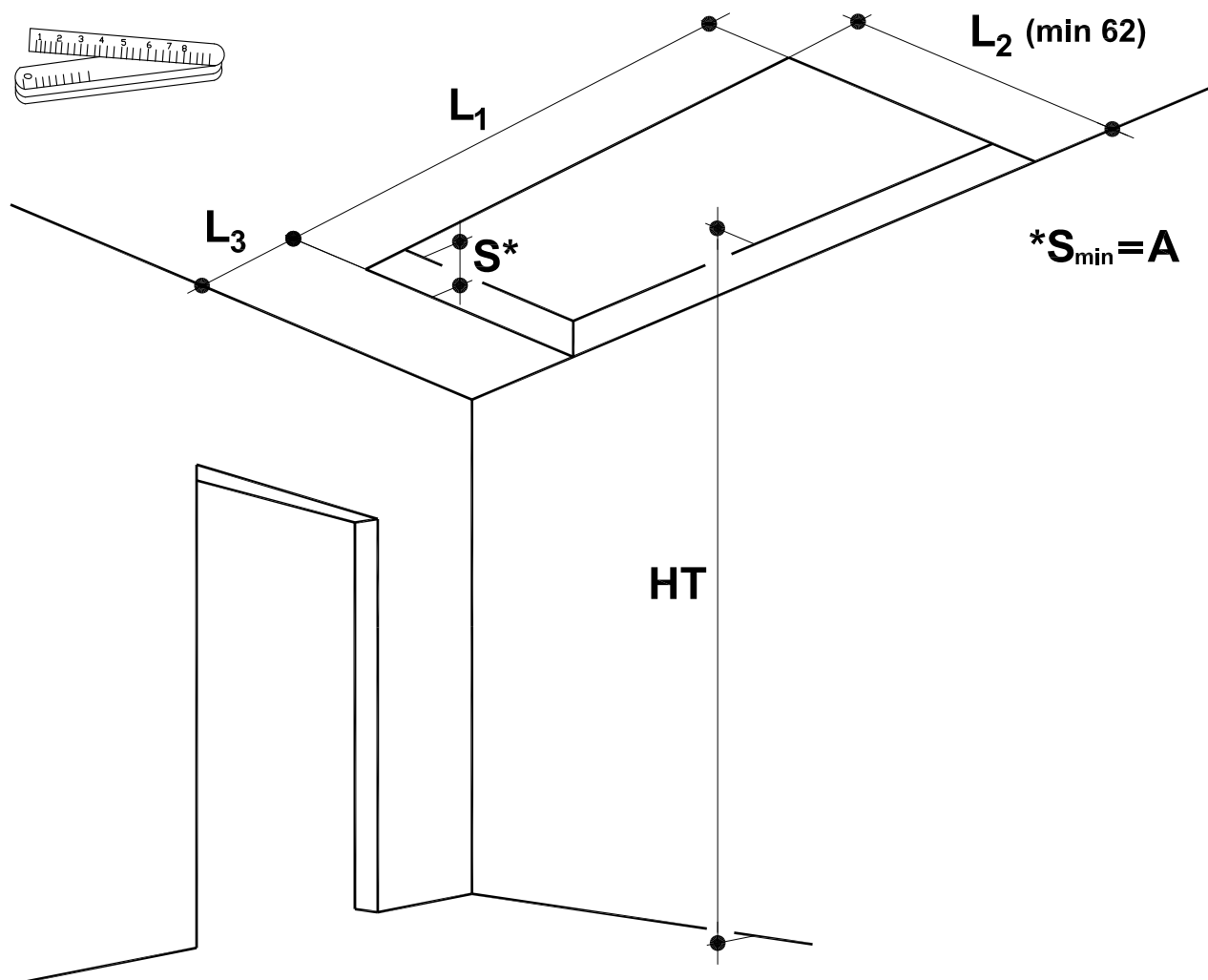

HT	$220 \leq HT \leq 260$	$240 \leq HT \leq 284$	$260 \leq HT \leq 308$	$280 \leq HT \leq 332$	$300 \leq HT \leq 356$
n	10	11	12	13	14
Y	137	149	161	173	185
L₁ min	138-150 *	138-174 *	138-186 *	138-186 *	138-186 *

* per il calcolo di L1 vedi tabelle pagina seguente / to determine L1 look at the following page / para el cálculo de L1 ver tablas en la página siguiente / pour le calcul de L1 voir les tableaux de la page suivante / zur Berechnung von L1 siehe Tabellen auf der folgenden Seite

Y ingombro scala a terra (pag. 4)/ floor space used downstairs (pag. 4)/ espacio ocupado por la escalera en el piso inferior (pag. 4)/ encombrement escalier au sol (pag. 4)/ Treppenausmass auf dem Boden (pag. 4)

tutte le dimensioni sono espresse in cm / all dimensions are expressed in cm / todas las dimensiones se expresan en cm / toutes les dimensions sont exprimées en cm / Alle Maße sind in cm angegeben

CALCOLO L1: valori minimi indicativi / DETERMINATION L1: indicative minimum values / CÁLCULO L1: valores mínimos indicativos / CALCUL L1: valeurs minimales indicatives / BERECHNUNG L1: indikative Mindestwerte

HT	n
220≤HT<225	10
S<30	150
S≥30	162

HT	n
225≤HT<230	10
S<35	150
S≥35	162

HT	n
230≤HT<235	10
20<S<40	150
S≥40	162

HT	n
235≤HT<240	10
S<25	138
25≤S<45	150
S≥45	162

HT	n	n
240≤HT<245	10	11
S≤30	138	150
30<S≤50	150	162

HT	n	n
245≤HT<250	10	11
S≤35	138	150
35<S≤55	150	162

HT	n	n
250≤HT<255	10	11
S≤40	138	150
40<S≤60	150	162

HT	n	n
255≤HT<260	10	11
S≤45	138	150
45<S≤65	150	162

HT	n	n
260≤HT<265	11	12
S≤25	138	150
25<S≤30	150	150
30<S≤50	150	162
50<S≤70	162	174

HT	n	n
265≤HT<270	11	12
S≤30	138	150
30<S<35	150	150
35≤S≤55	150	162
55<S≤75	162	174

HT	n	n
270≤HT<275	11	12
	138	150
35<S<40	150	150
40≤S≤60	150	162
60<S≤80	162	174

HT	n	n
275≤HT<280	11	12
S≤40	138	150
40<S<45	150	150
45≤S≤65	150	162
65<S≤85	162	174

HT	n	n	n
280≤HT<285	11	12	13
S≤45	138	150	162
45<S≤50	150	162	162
50<S≤70	150	162	174
70<S≤90	162	174	174

HT	n	n
285≤HT<290	12	13
S≤30	138	150
30<S<55	150	162
55≤S<80	162	174
80≤S≤95	174	186

HT	n	n
290≤HT<295	12	13
S≤35	138	150
35<S≤55	150	162
55<S≤80	162	174
80<S≤100	174	186

HT	n	n
295≤HT<300	12	13
S≤35	138	150
35<S≤55	150	162
55<S≤80	162	174
80<S≤105	174	186

HT	n	n	n
300≤HT<305	12	13	14
S≤30	138	150	150
30<S≤40	138	150	162
40<S<55	150	162	162
55≤S≤65	150	162	174
65<S≤90	162	174	186

HT	n	n	n
305≤HT<310	12	13	14
S<35	138	150	150
35≤S≤35	138	150	162
45<S<55	150	162	162
55≤S≤70	150	162	174
70<S≤95	162	174	186

HT	n	n
310≤HT<315	13	14
S≤30	138	150
30<S≤55	150	162
55<S≤75	162	174
75<S≤100	174	186

HT	n	n
315≤HT<320	13	14
S≤35	138	150
35<S≤55	150	162
55<S≤80	162	174
80<S≤105	174	186

HT	n	n
320≤HT<325	13	14
S≤40	138	150
40<S≤65	150	162
65≤S≤85	162	174
85<S≤110	174	186

HT	n	n
325≤HT<330	13	14
S<45	138	150
45≤S<70	150	162
70≤S≤90	162	174
90<S≤115	174	186

HT	n	n
330≤HT<335	13	14
S≤30	138	138
30<S<50	138	150
50≤S≤70	150	162
70<S≤95	162	174
95<S≤120	174	186

HT	n
335≤HT<340	14
S≤35	138
35<S<60	150
60≤S≤80	162
80<S≤100	174
100<S≤125	186

HT	n
340≤HT<345	14
S≤35	138
35<S<65	150
65≤S≤80	162
80<S≤100	174
100<S≤125	186

HT	n
345≤HT<350	14
S≤40	138
40<S≤65	150
65<S<90	162
90≤S≤110	174
110<S≤135	186

HT	n
350≤HT<356	14
S≤45	138
45<S<70	150
70≤S≤90	162
90<S≤115	174
110<S≤140	186

INGOMBRO SCALA A TERRA (Y) / FLOOR SPACE USED DOWNSTAIRS (Y) / ESPACIO OCUPADO POR LA ESCALERA EN EL PISO INFERIOR (Y) / ENCOMBREMENT ESCALIER AU SOL (Y) / TREPPENAUSMASS AUF DEM BODEN (Y)

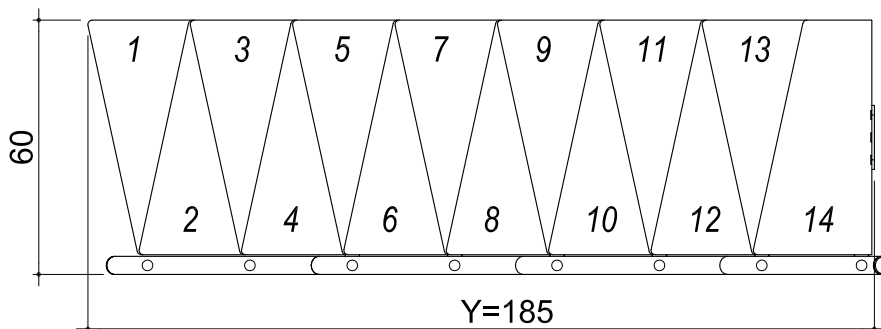
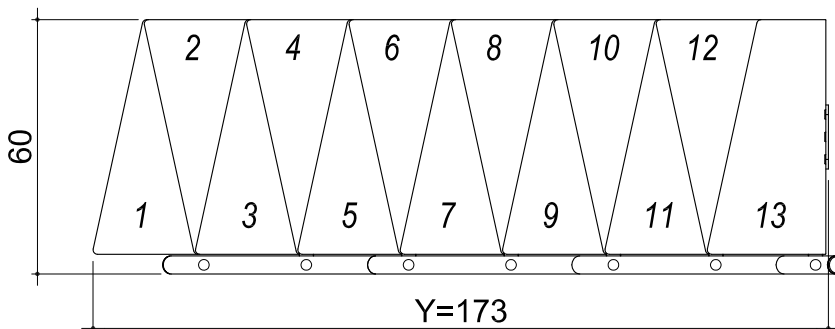
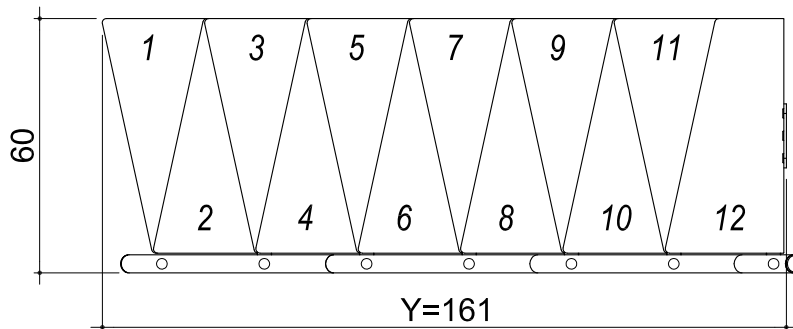
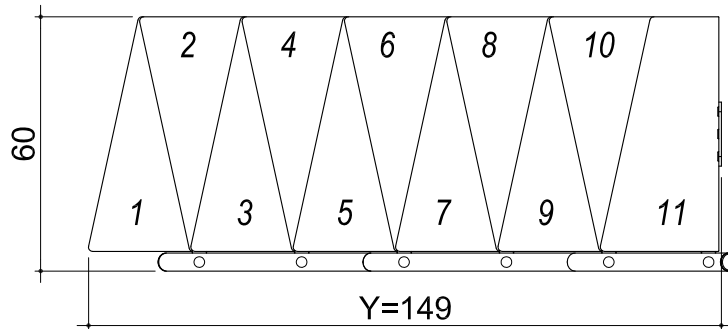
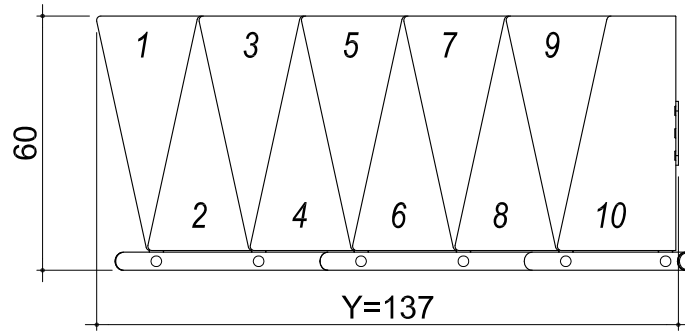

UTENSILI NECESSARI / NECESSARY TOOLS / HERRAMIENTAS NECESARIAS / OUTILS NÉCESSAIRES / NOTWENDIGE WERKZEUGE



COMPONENTI DELLA SCALA / COMPONENTS OF THE STAIR / COMPONENTES DE LA ESCALA / COMPOSANTS DE L'ESCALIER / TREPPEN-KOMPONENTEN

SCALA 11 GRADINI / STAIR 11 STEPS / ESCALERA 11 PELDAÑOS / ESCALIER 11 MARCHES / TREPPE 11 STUFEN

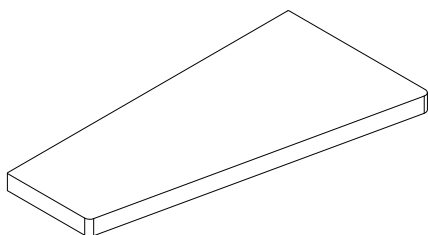

110000812
x 11

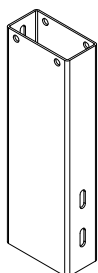

600651001/22
x 10

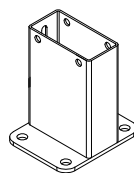

600650001/22
x 1

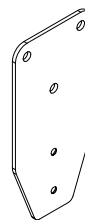

600653001/22
x 1

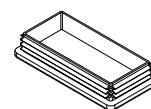

640074401/22
x 10

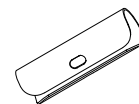

600409314
x 2

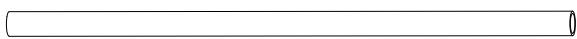

996400101/22
x 3

Ø 4,2 L=100



600271501/22
x 1

Ø 2,5 L=140



600269001/22
x 5

Ø 2,5 L=116

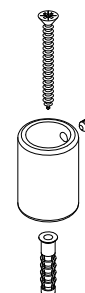

703230101/22
x 1



640095014
x 2



640650501/22
x 2



640069501/22
x 1

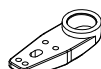

640070101/22
x 16



640079101/22
x 5



640068101/22
x 44

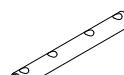

600410010
x 22



640064601/22
x 6



640064701/22
x 6

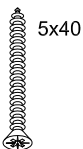

630142509
x 44

5x40



630142009
x 12

5x20

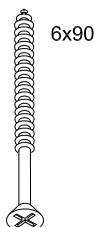

630145510
x 1

6x90



640081014
x 1



630201009
x 17

4x20



640064501/22
x 6



640064801/22
x 6

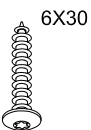

630113910
x 16

6X30

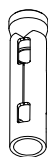

630333010
x 7



630180010
x 7

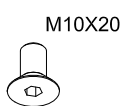

630135110
x 2

M10X20



630111910
x 20

M10X20

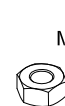

630102710
x 22

M10



630144810
x 6

M6X50

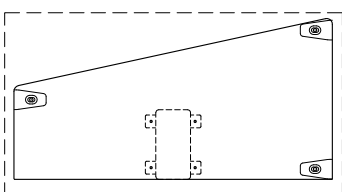

650536500
x 1

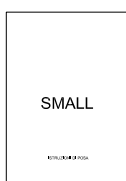

650535100
x 1

SMALL

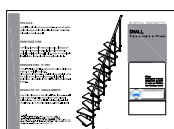

650536100
x 1

M10X18



630102909
x 7



630330210
x 42



630102010
x 6

M6

COMPONENTI DELLA SCALA / COMPONENTS OF THE STAIR / COMPONENTES DE LA ESCALA / COMPOSANTS DE L'ESCALIER / TREPPEN-KOMPONENTEN

SCALA 10 GRADINI / STAIR 10 STEPS / ESCALERA 10 PELDAÑOS / ESCALIER 10 MARCHES / TREPPE 10 STUFEN

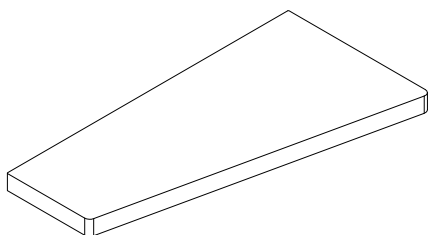

110000812
x 10

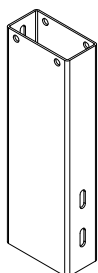

600651001/22
x 9

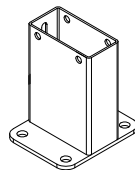

600650001/22
x 1

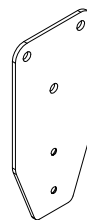

600653001/22
x 1

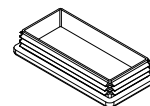

640074401/22
x 9

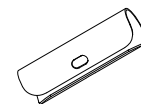

600409314
x 2



996400101/22
x 3

Ø 4,2 L=100



600271501/22
x 1

Ø 2,5 L=140



600269001/22
x 4

Ø 2,5 L=116

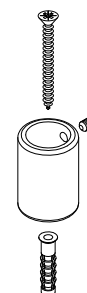

703230101/22
x 1



640095014
x 2



640650501/22
x 2



640069501/22
x 1

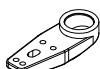

640070101/22
x 15



640079101/22
x 4



640068101/22
x 40

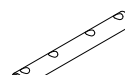

600410010
x 20



640064601/22
x 5



640064701/22
x 5

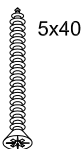

630142509
x 40

5x40



630142009
x 10

5x20

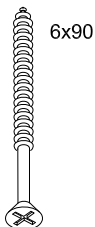

630145510
x 1

6x90



640081014
x 1



630201009
x 16

4x20



640064501/22
x 5



640064801/22
x 5

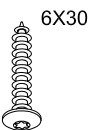

630113910
x 15

6X30

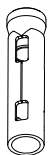

630333010
x 7



630180010
x 7

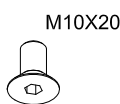

630135110
x 2

M10X20



630111910
x 18

M10X20



630102710
x 20

M10

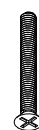

630144810
x 5

M6X50

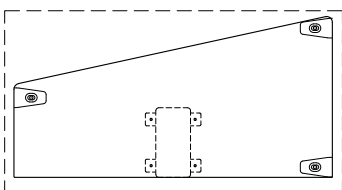

650536500
x 1

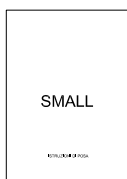

650535100
x 1

SMALL

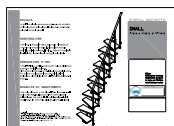

650536100
x 1

M10X18



630102909
x 7



630330210
x 38



630102010
x 5

M6

COMPONENTI DELLA SCALA / COMPONENTS OF THE STAIR / COMPONENTES DE LA ESCALA / COMPOSANTS DE L'ESCALIER / TREPPEN-KOMPONENTEN

GRADINO SUPPLEMENTARE / ADDITIONAL STEP / PELDAÑO ADICIONAL / MARCHE SUPPLÉMENTAIRE / ZUSÄTZLICHER STUFEN

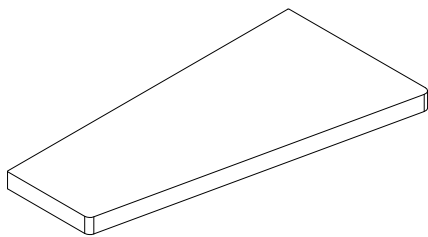

110000812
x 1

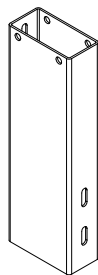

600651001/22
x 1

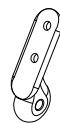

640064601/22
x 1

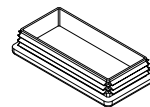

640074401/22
x 1



640064701/22
x 1

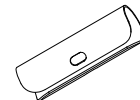

600409314
x 1

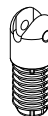

640064501/22
x 1

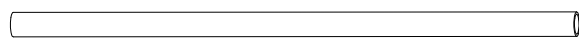

996400101/22 \varnothing 4,2 L=100
x 1



640064801/22
x 1

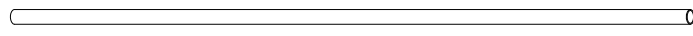

600269001/22 \varnothing 2,5 L=116
x 1



640095014
x 1

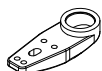

640070101/22
x 2



640079101/22
x 1



640068101/22
x 4

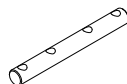

600410010
x 2



630142509
x 4



630330210
x 4



630142009
x 2



630144810
x 1



630201009
x 2

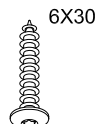

630113910
x 2

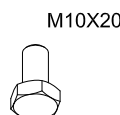

630111910
x 2



630102710
x 2



630102010
x 1

FISSAGGIO SCALA AL SOLAIO / HOW TO FIX THE STAIR TO THE SLAB / FIJACIÓN DE LA ESCALERA AL FORJADO / FIXATION DE L'ESCALIER À LA DALLE / TREPPENBEFESTIGUNG AAN DER ZIMMERDECKE

1

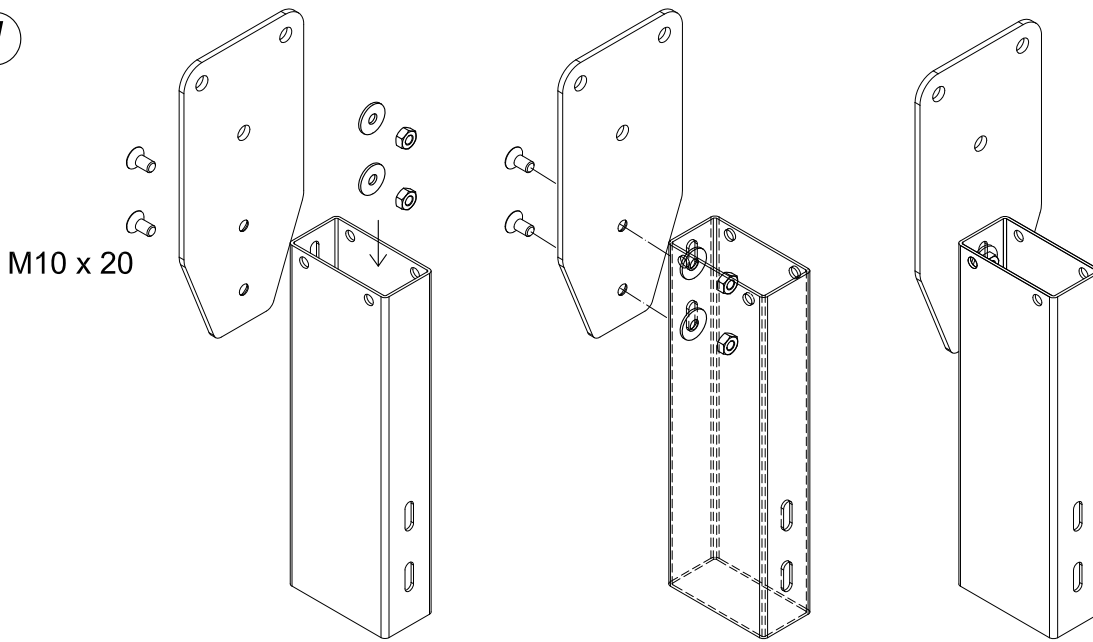

2

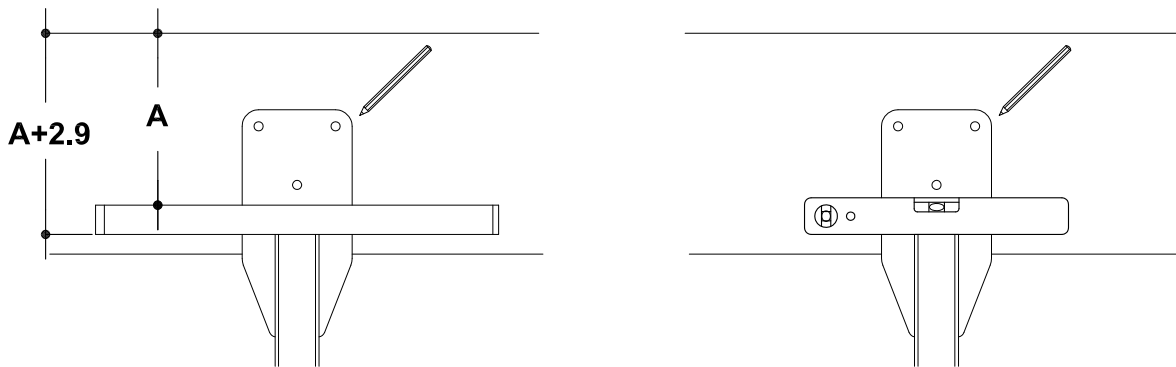

3

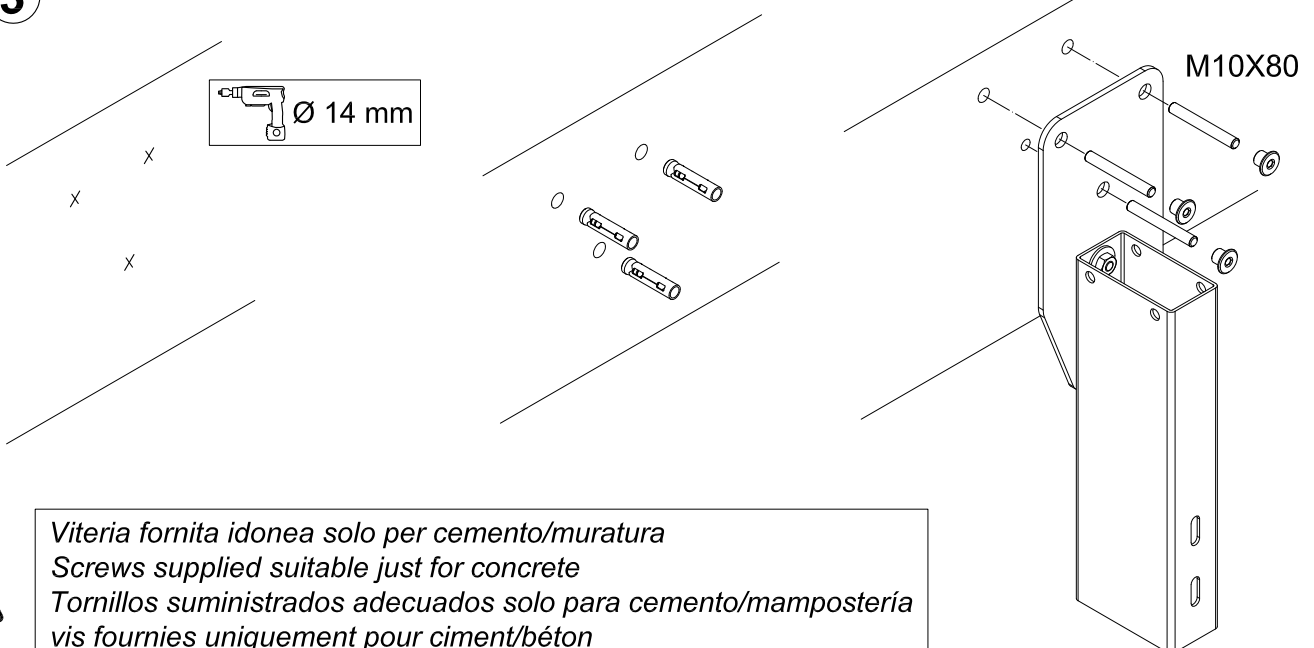

*Viteria fornita idonea solo per cemento/muratura
Screws supplied suitable just for concrete
Tornillos suministrados adecuados solo para cemento/mampostería
vis fournies uniquement pour ciment/béton
Gelieferte Schrauben nur für Beton/Mauerwerk geeignet*

ASSEMBLAGGIO STRUTTURE / STRUCTURE ASSEMBLY / MONTAJE DE LAS ESTRUCTURAS / ASSEMBLAGE DE STRUCTURES / STRUKTUREN-MONTAGE

4

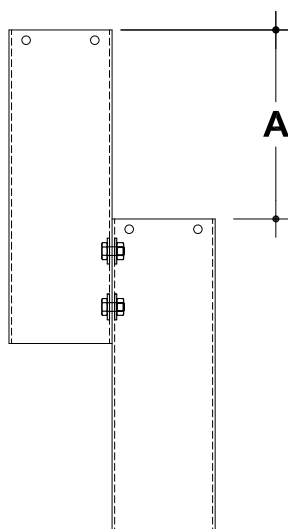
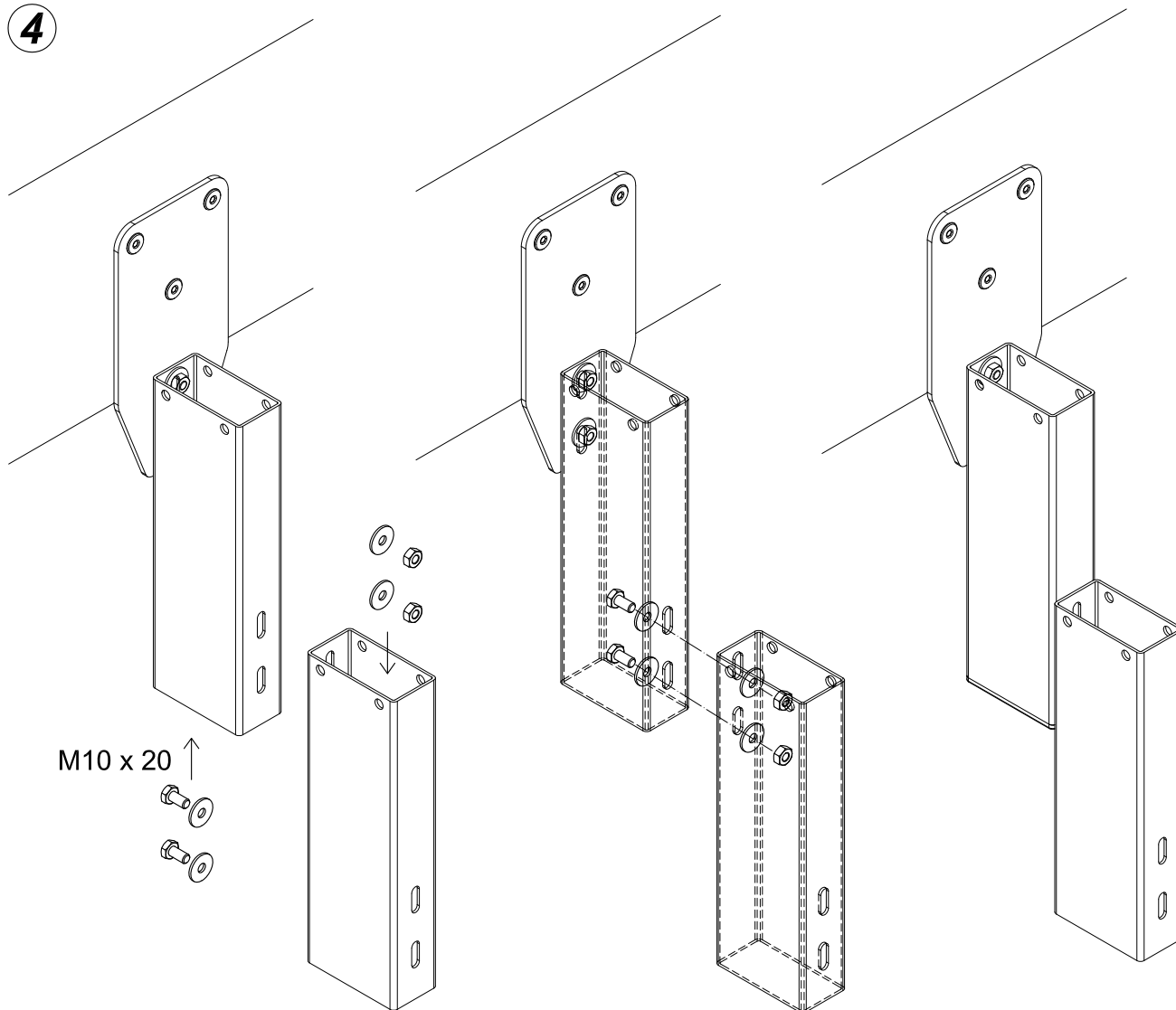

5

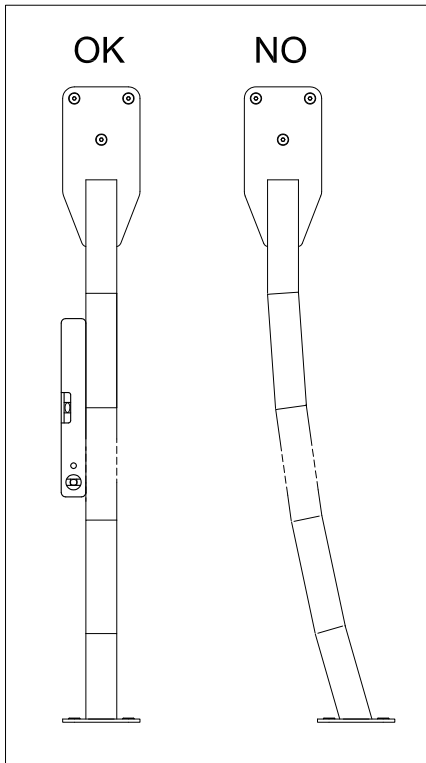
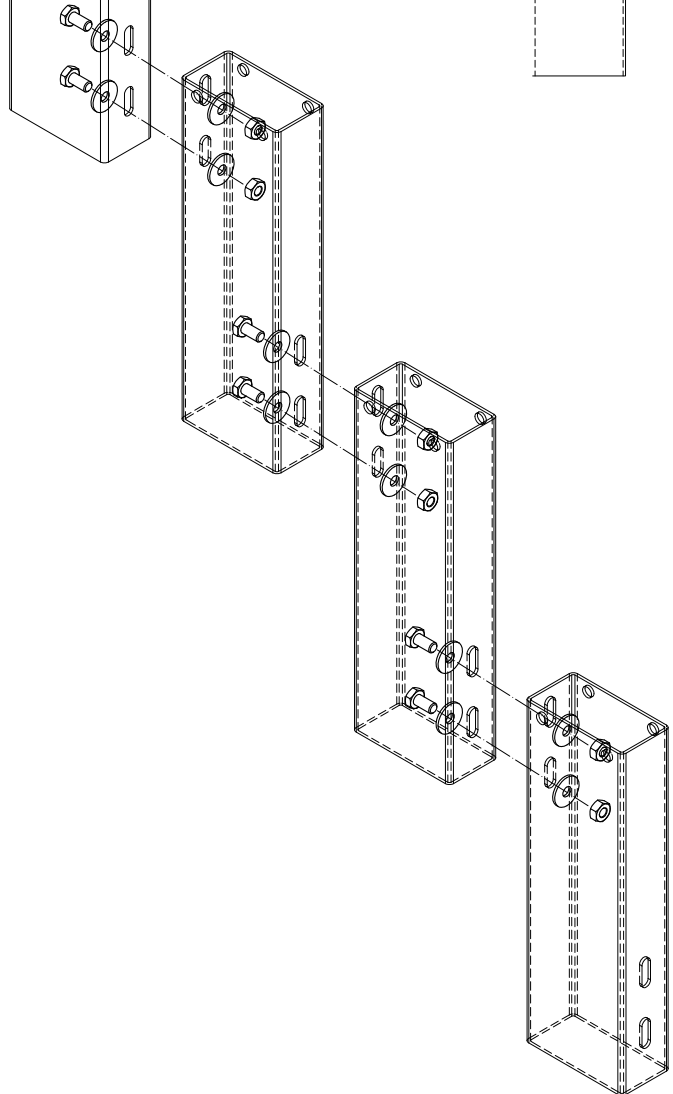
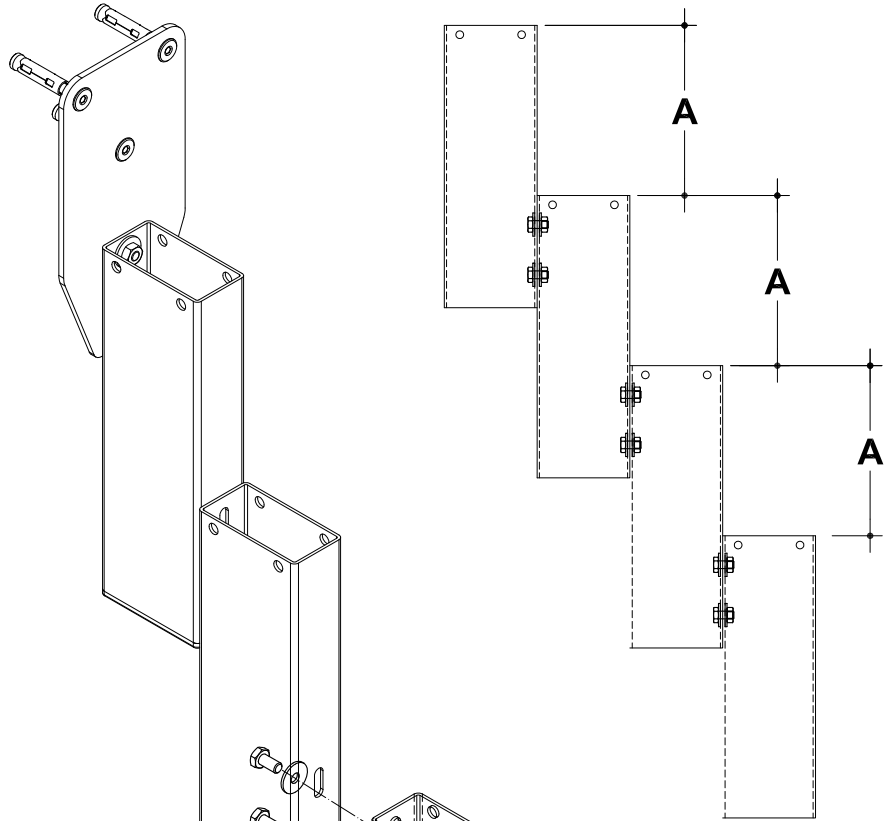

6

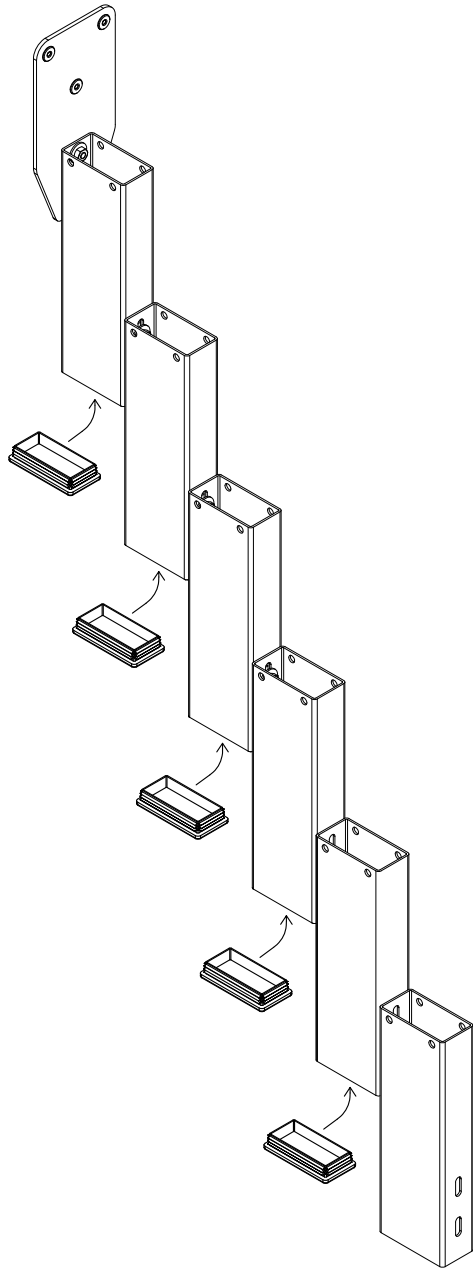

7

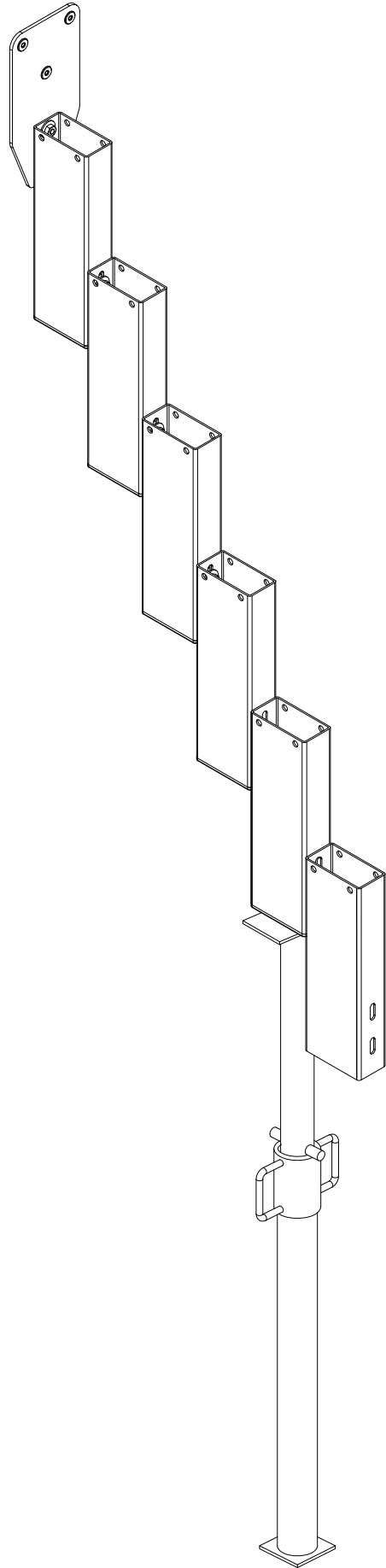

8

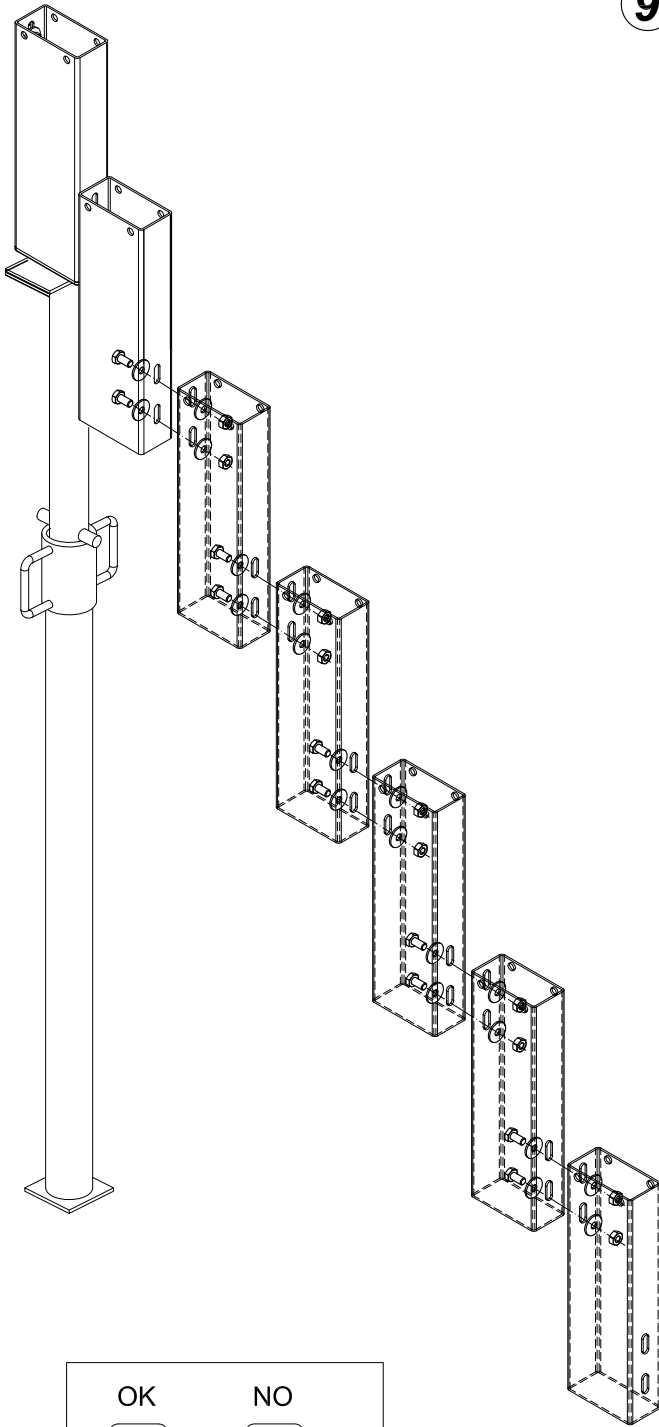

9

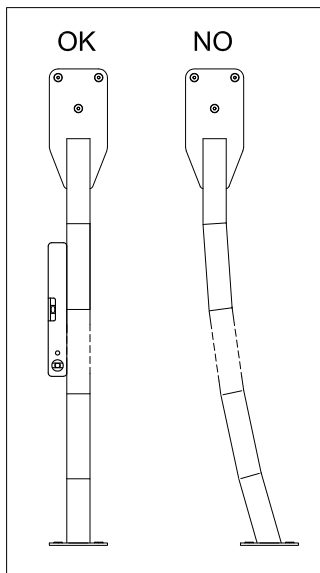
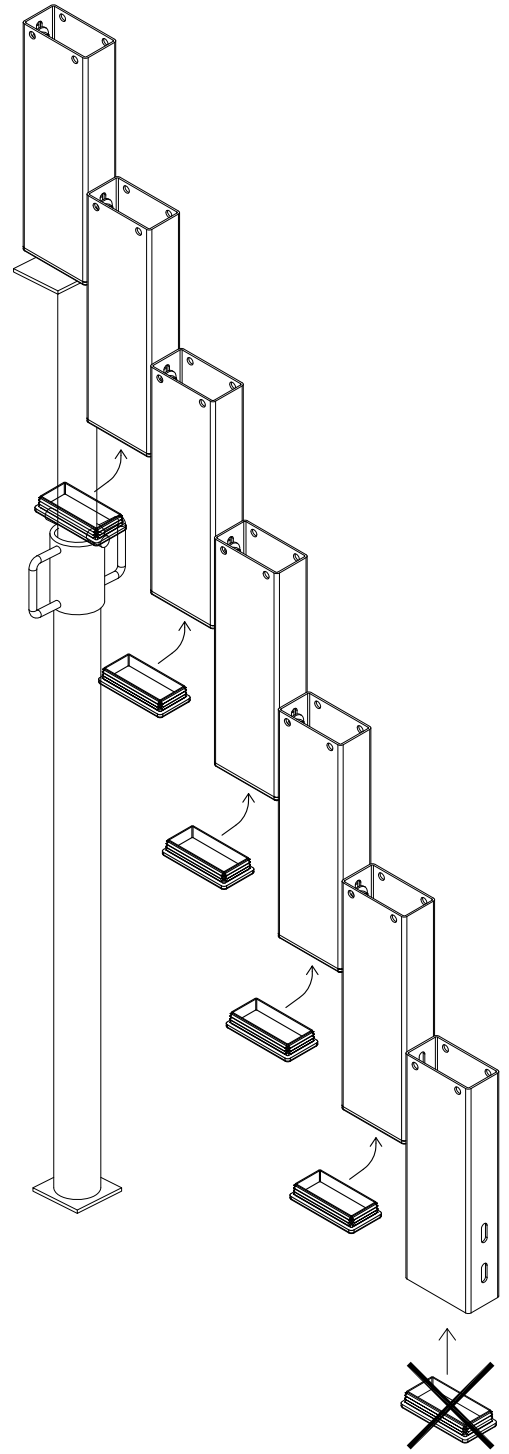

10

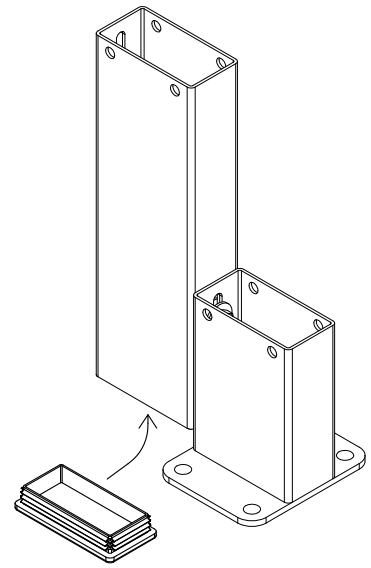
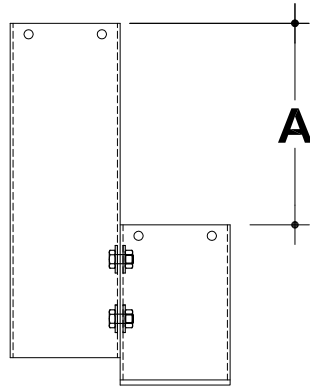
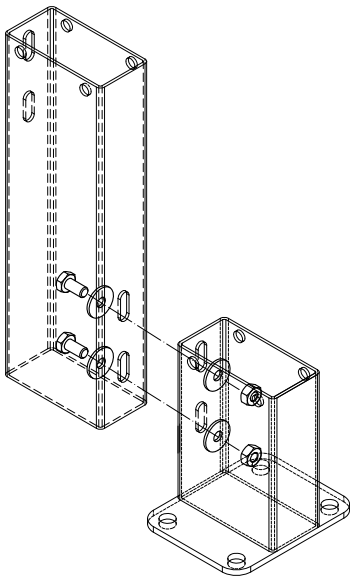

11

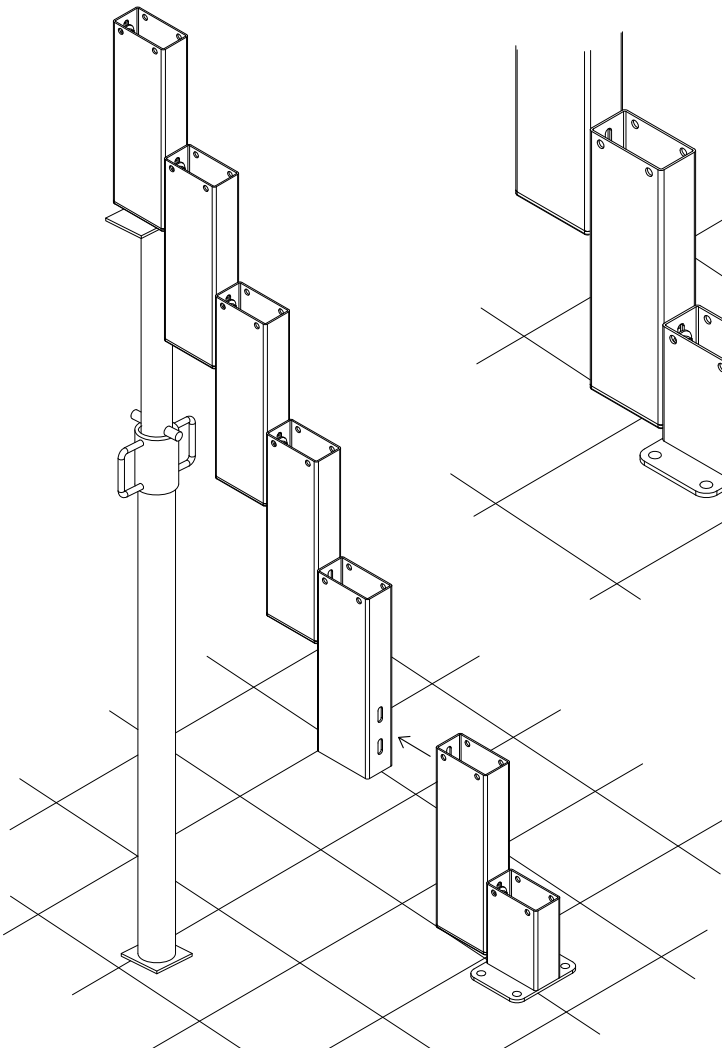

12

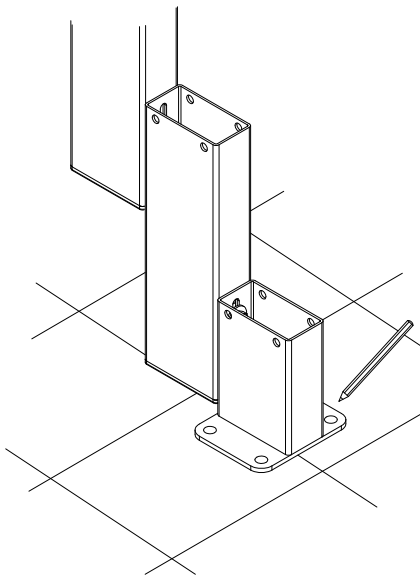

13

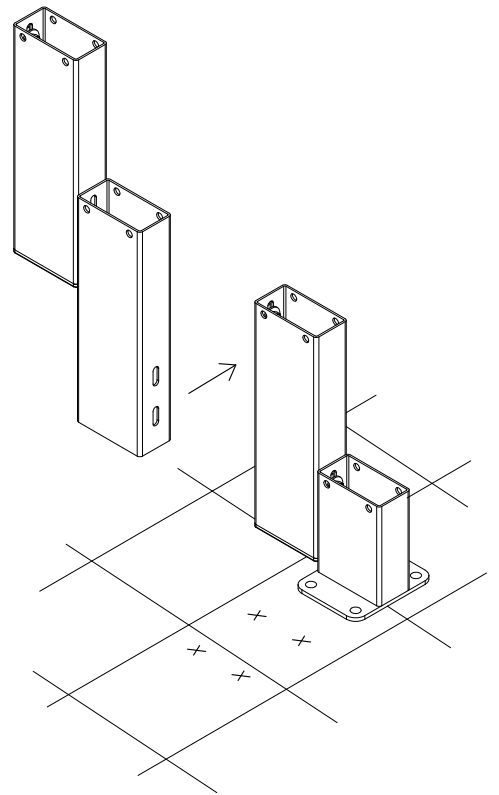

14

Ø 14 mm

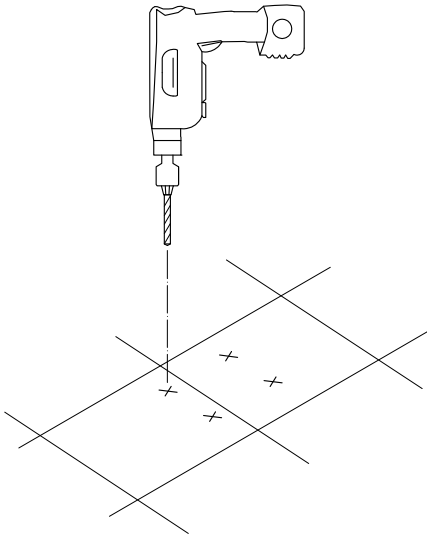

15

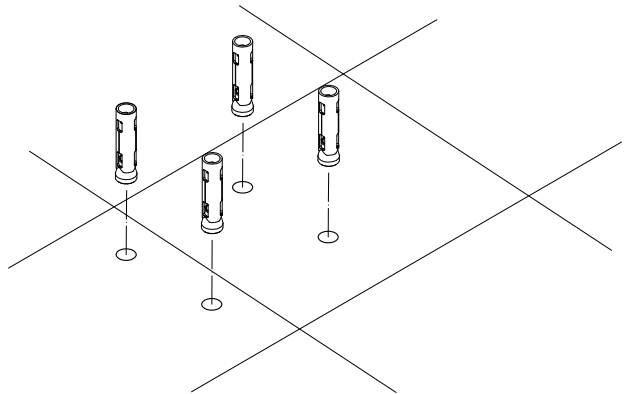

16

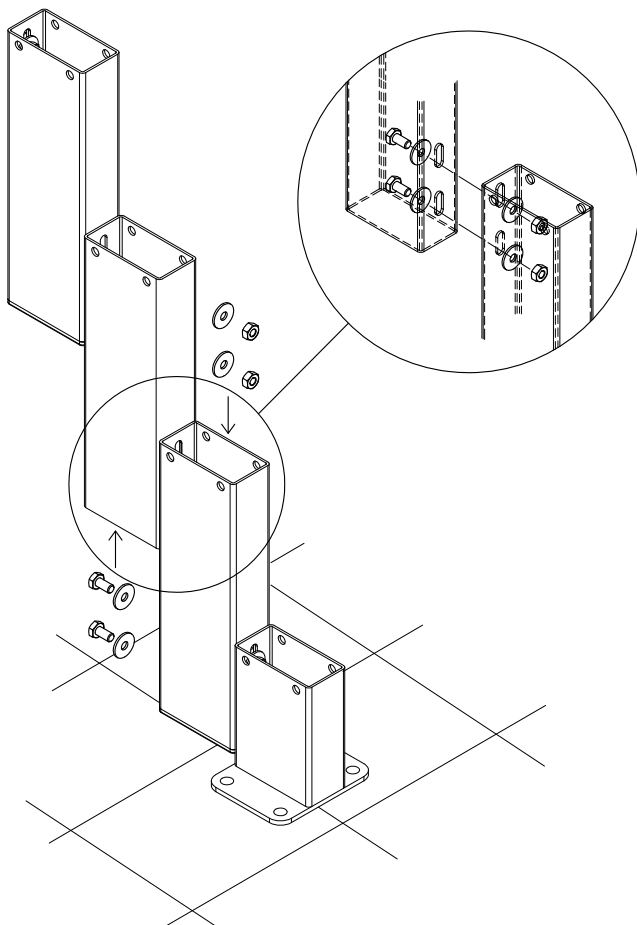

17

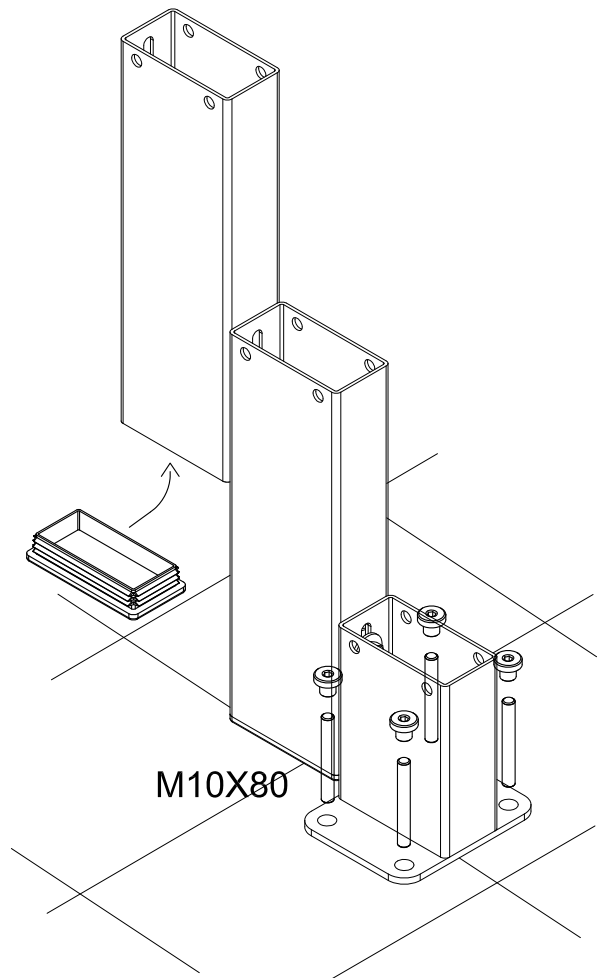

PUNZONATURA GRADINO DI SBARCO / PUNCHING OF THE LANDING / TROQUELADURA DEL DESEMBARCO / POINÇONNAGE PALIER D'ARRIVÉE / BOHRUNGEN AM TREPPENAUSTRITT

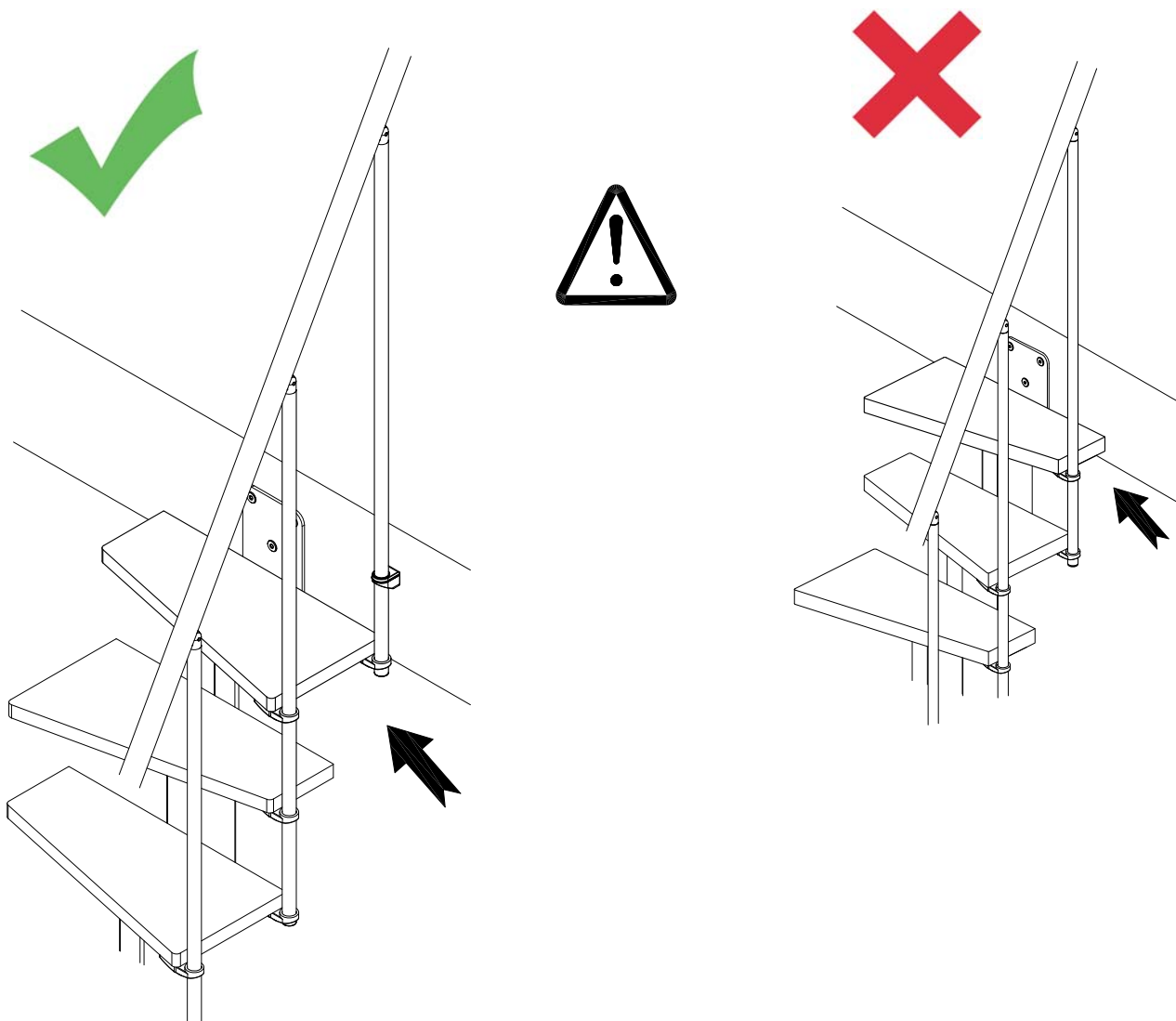

18

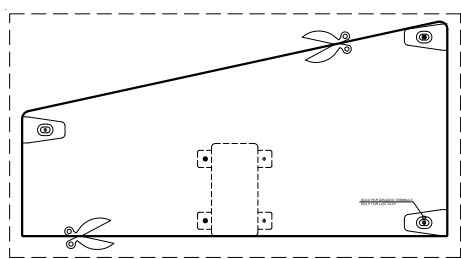

19

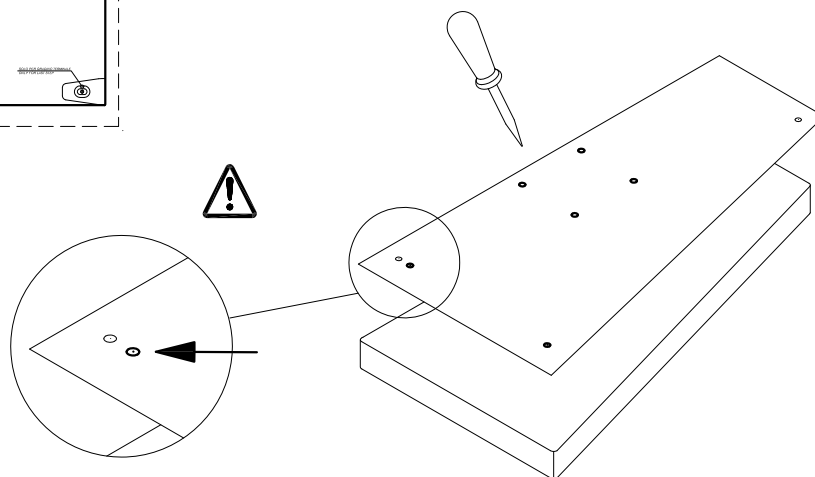

PUNZONATURA ALTRI GRADINI: ringhiera lato destro / PUNCHING OF OTHER STEPS: railing on the right side /
TROQUELADURA OTROS PELDAÑOS: barandilla lateral derecha / POINÇONNAGE D'AUTRES MARCHES: rampe
droite / BOHRUNGEN AN ANDERN STUFEN: Geländer auf der rechten Seite

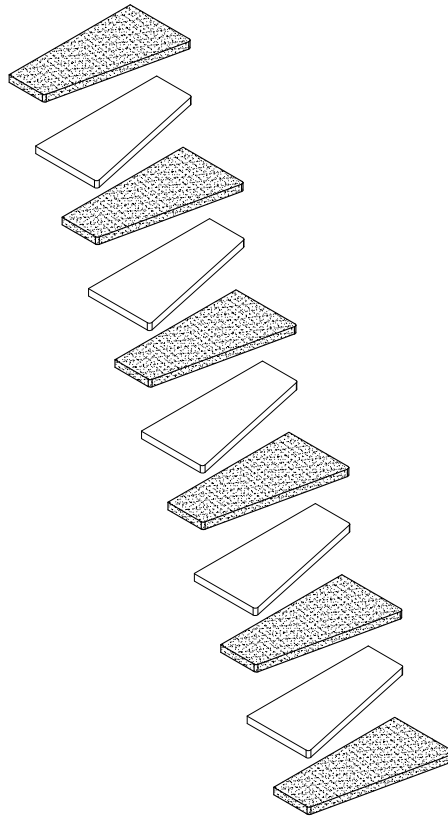
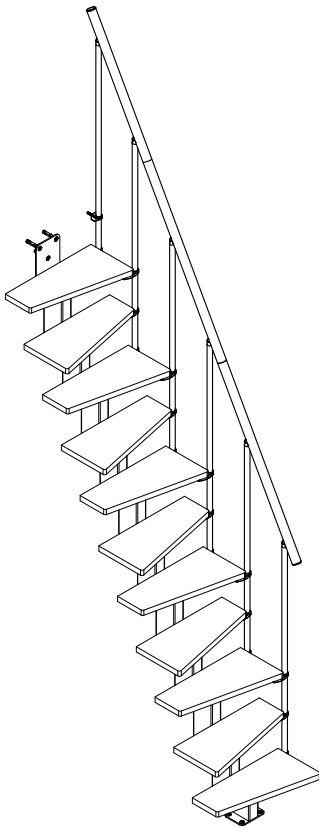

20

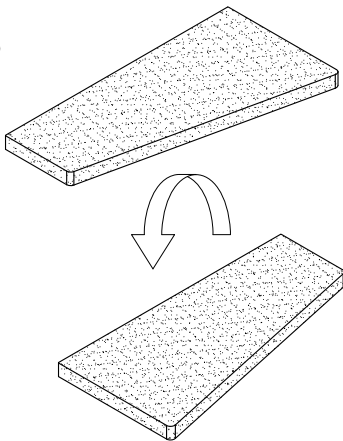

22

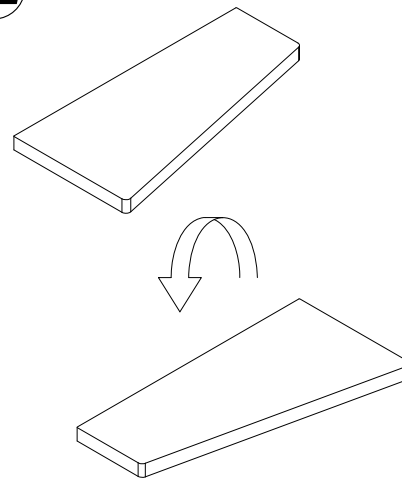

21

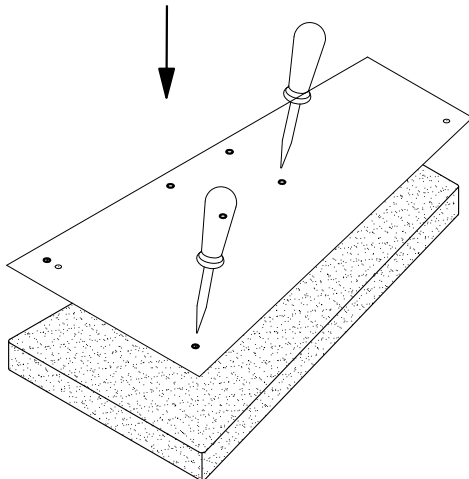

23

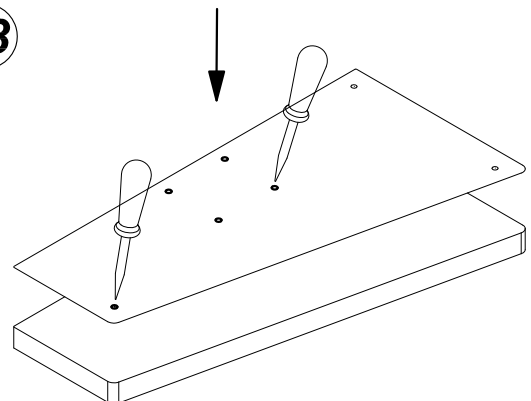

PUNZONATURA ALTRI GRADINI: ringhiera lato sinistro / PUNCHING OF OTHER STEPS: railing on the left side /
TROQUELADURA OTROS PELDAÑOS: barandilla lateral izquierda / POINÇONNAGE D'AUTRES MARCHES: rampe
gauche / BOHRUNGEN AN ANDERN STUFEN: Geländer auf der linken Seite

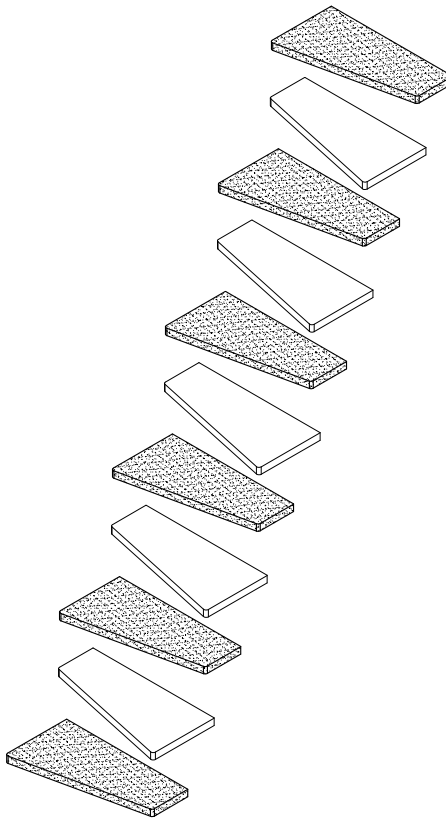
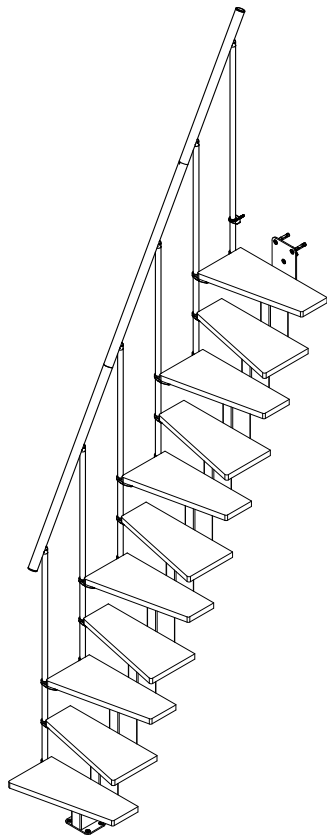

20

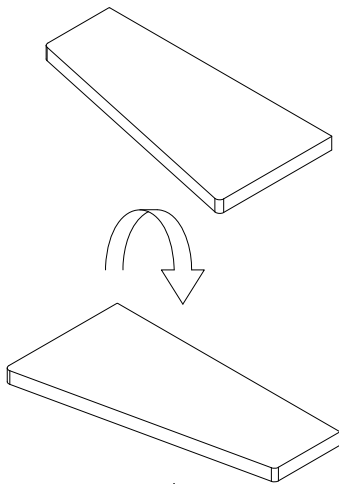

21

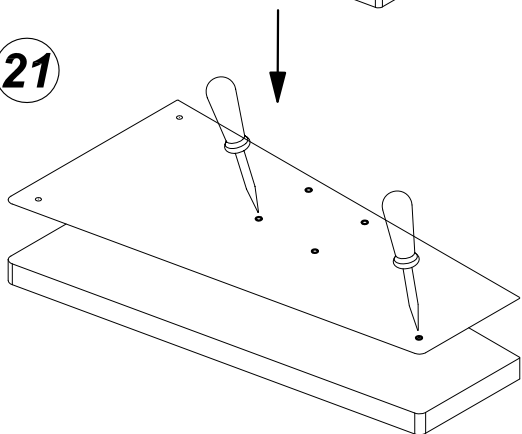

22

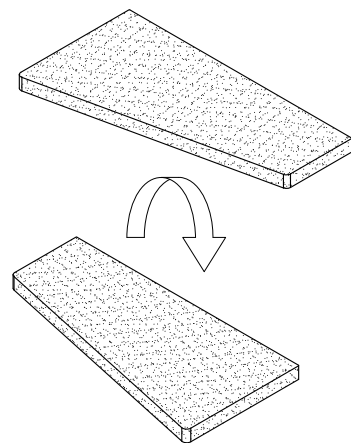

23

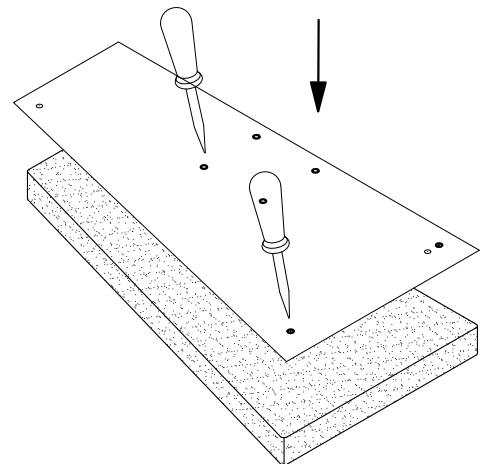

24

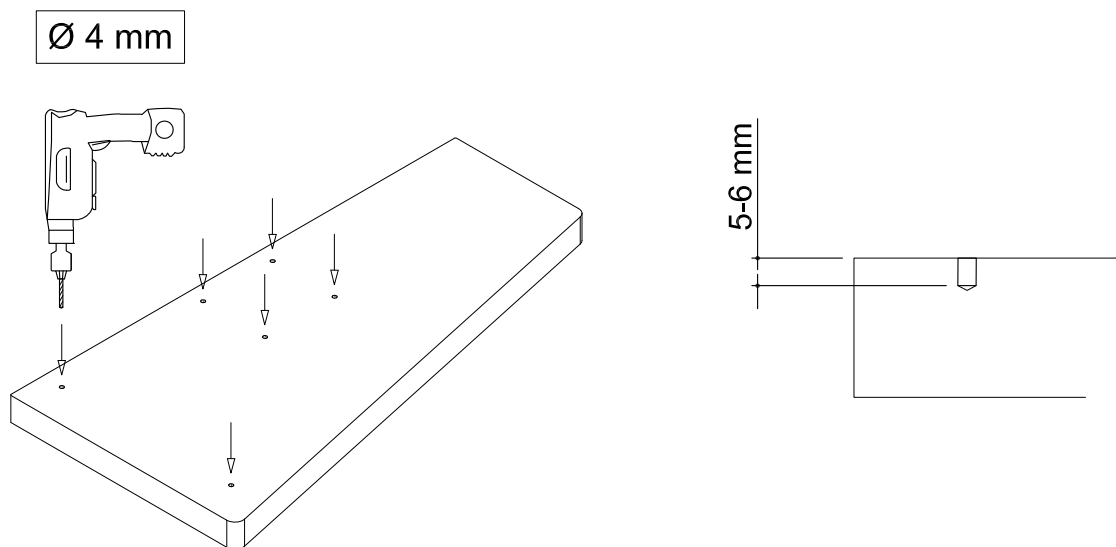

FISSAGGIO COLLEGAMENTO COLONNA-GRADINO / COLUMN-STEP CONNECTION FIXING / FIJACIÓN DE CONEXIÓN COLUMNA-PELDAÑO / FIXATION TUBE-MARCHE / VERBINDUNGSBEFESTIGUNG ZWISCHEN GELÄNDERSÄLE UND STUFE

25

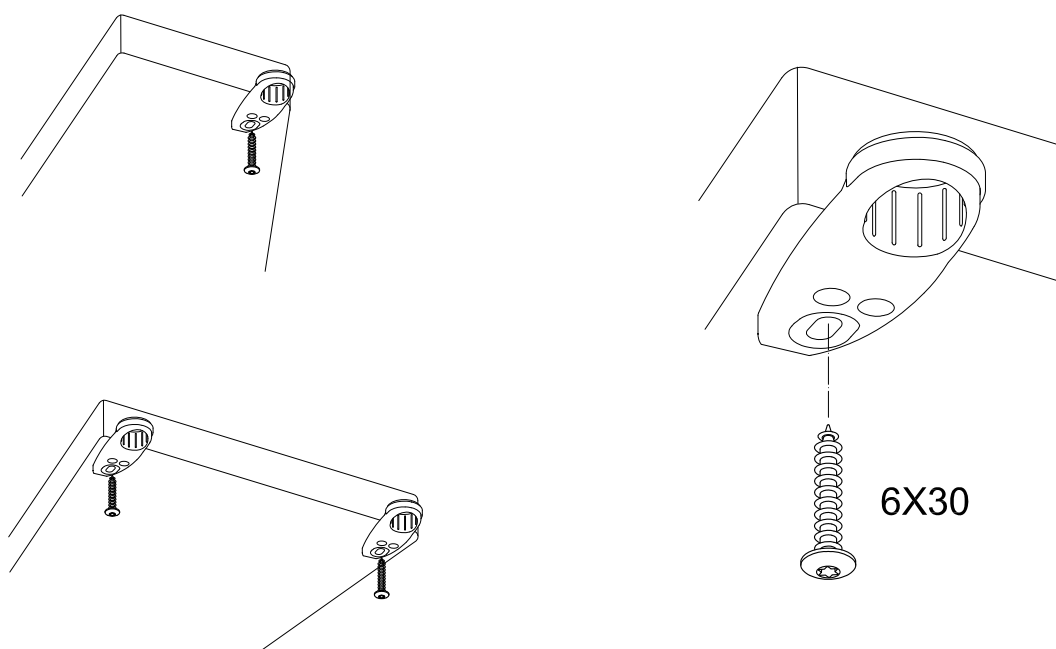

FISSAGGIO GRADINI ALLE STRUTTURE / FIXING STEPS TO THE STRUCTURES / FIJACIÓN DE LOS PELDAÑOS A LAS ESTRUCTURAS / FIXATION MARCHES À LA STRUCTURE / VERBINDUNGSBEFESTIGUNG DER STUFEN AN DEN STRUKTUREN

26

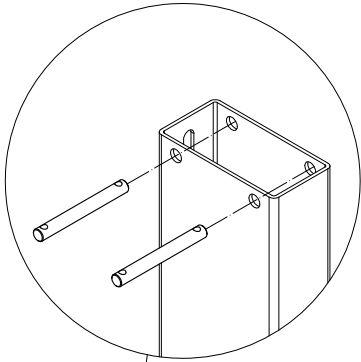

27

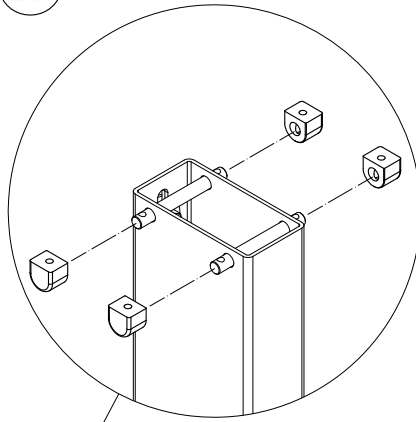

28

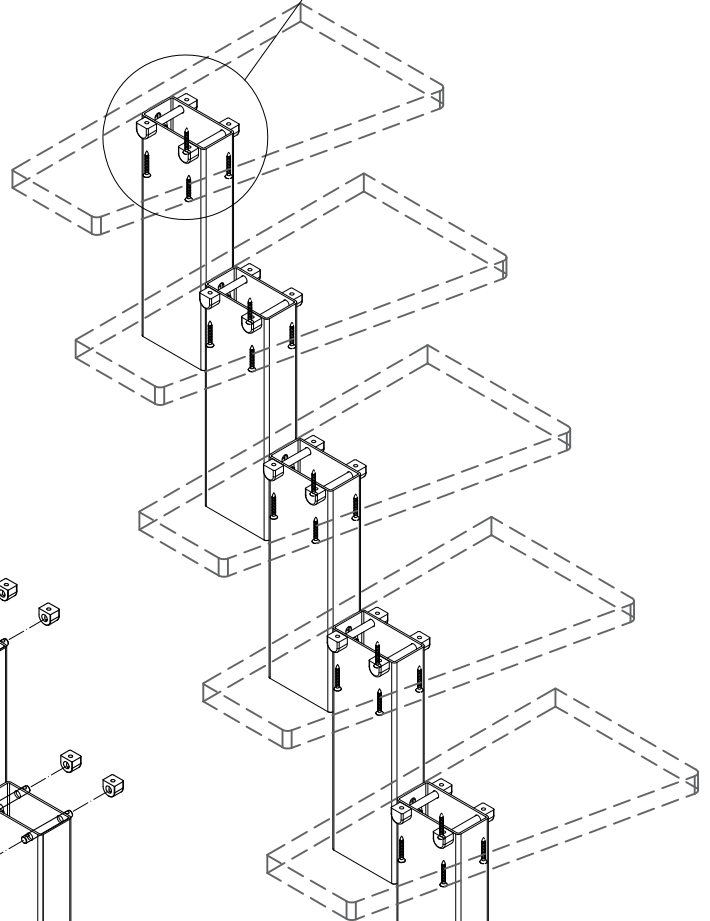
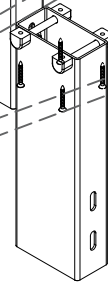
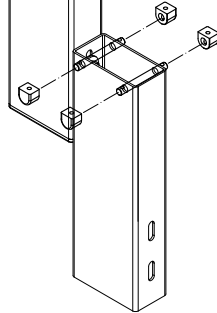
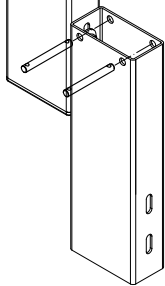
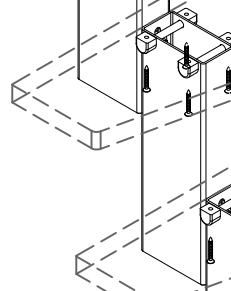
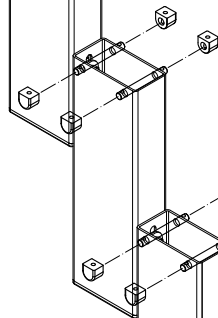
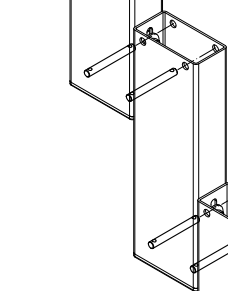
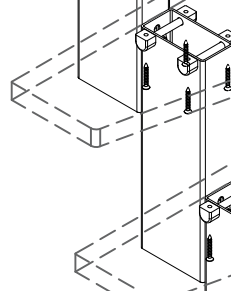
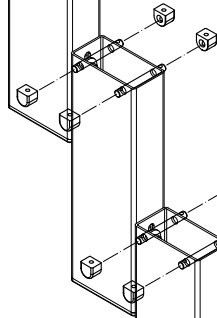
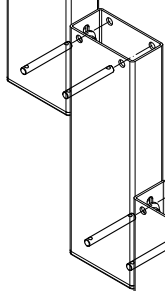
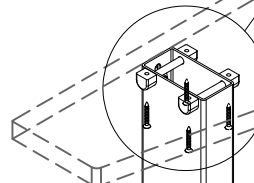
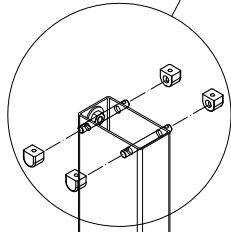
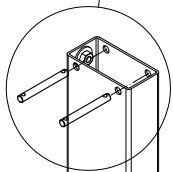
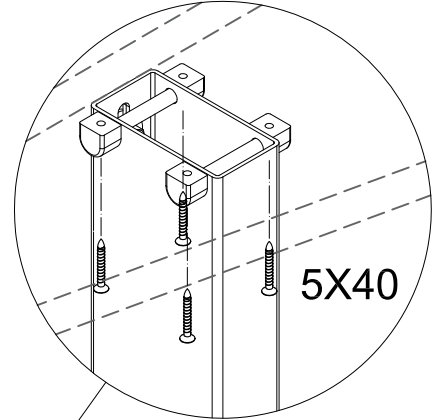

ASSEMBLAGGIO COLLEGAMENTI COLONNA-CORRIMANO / COLUMN-HANDRAIL CONNECTIONS ASSEMBLY /
MONTAJE CONEXIONES COLUMNAS - PASAMANO / ASSEMBLAGE RACCORD COLONNE-MAIN COURANTE /
VERBINDUNG ZWISCHEN GELÄNDERSÄULE UND HANDLAUF

29

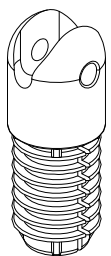

1

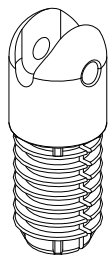

2

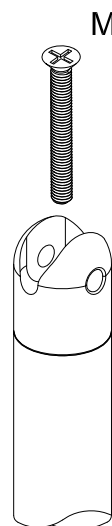
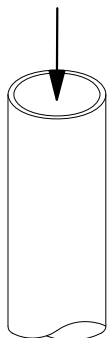

M6x50

3

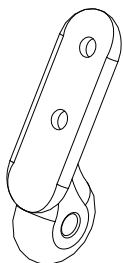

4

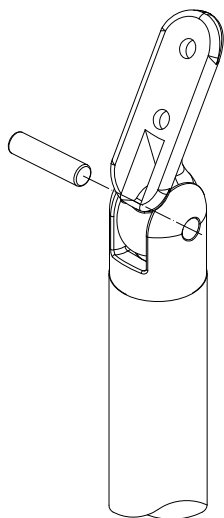
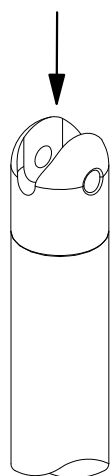

5

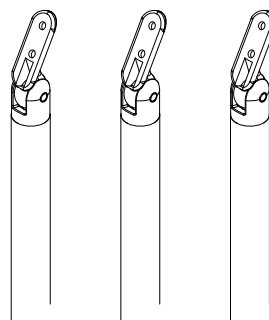
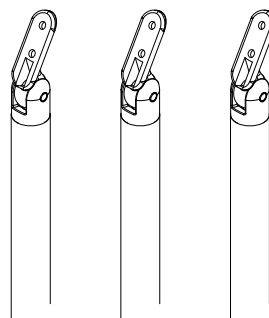

ASSEMBLAGGIO COLONNE / COLUMNS ASSEMBLY / MONTAJE COLUMNAS / ASSEMBLAGE COLONNES /
GELÄNDERSÄULEN-MONTAGE

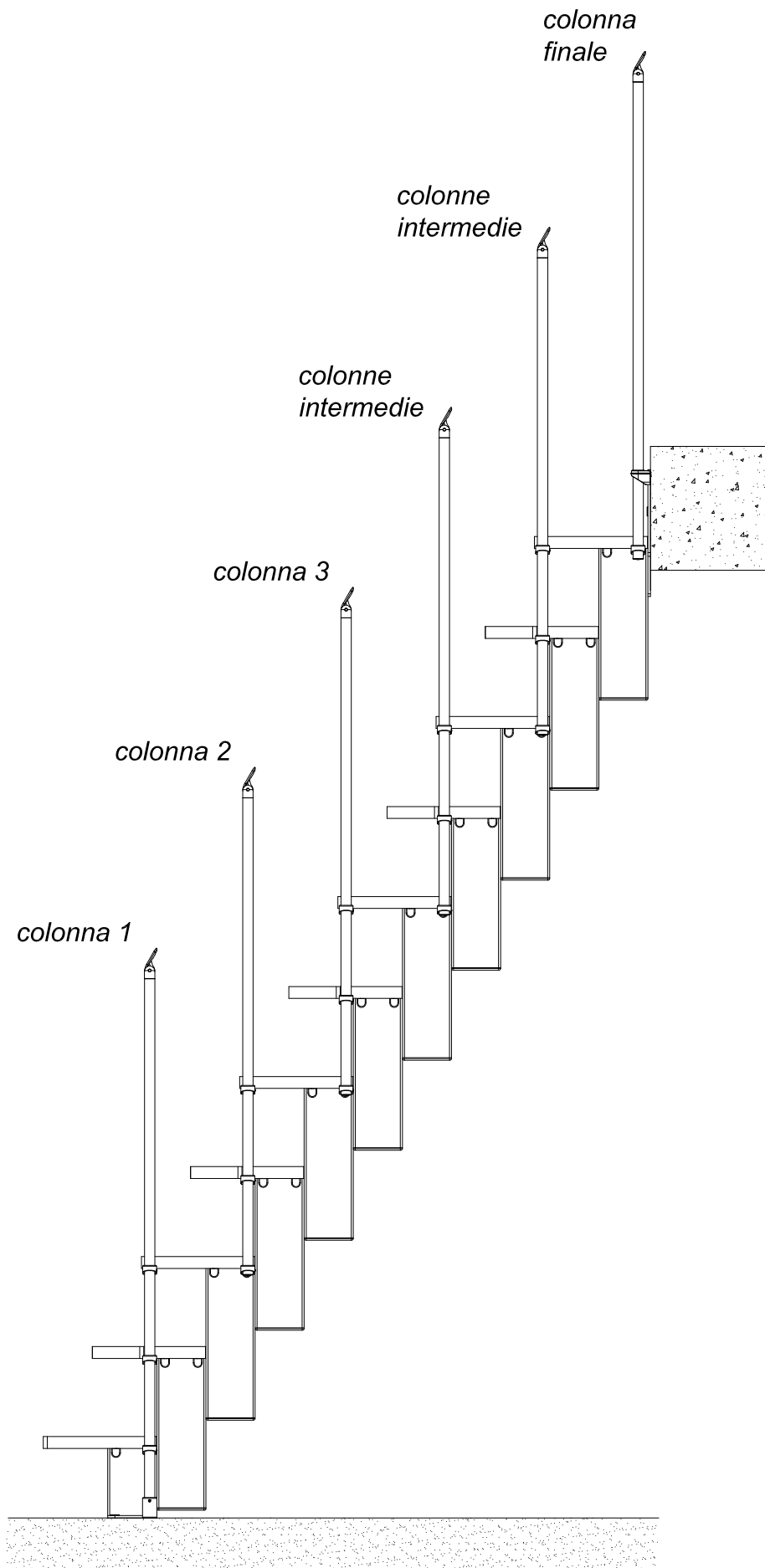

30

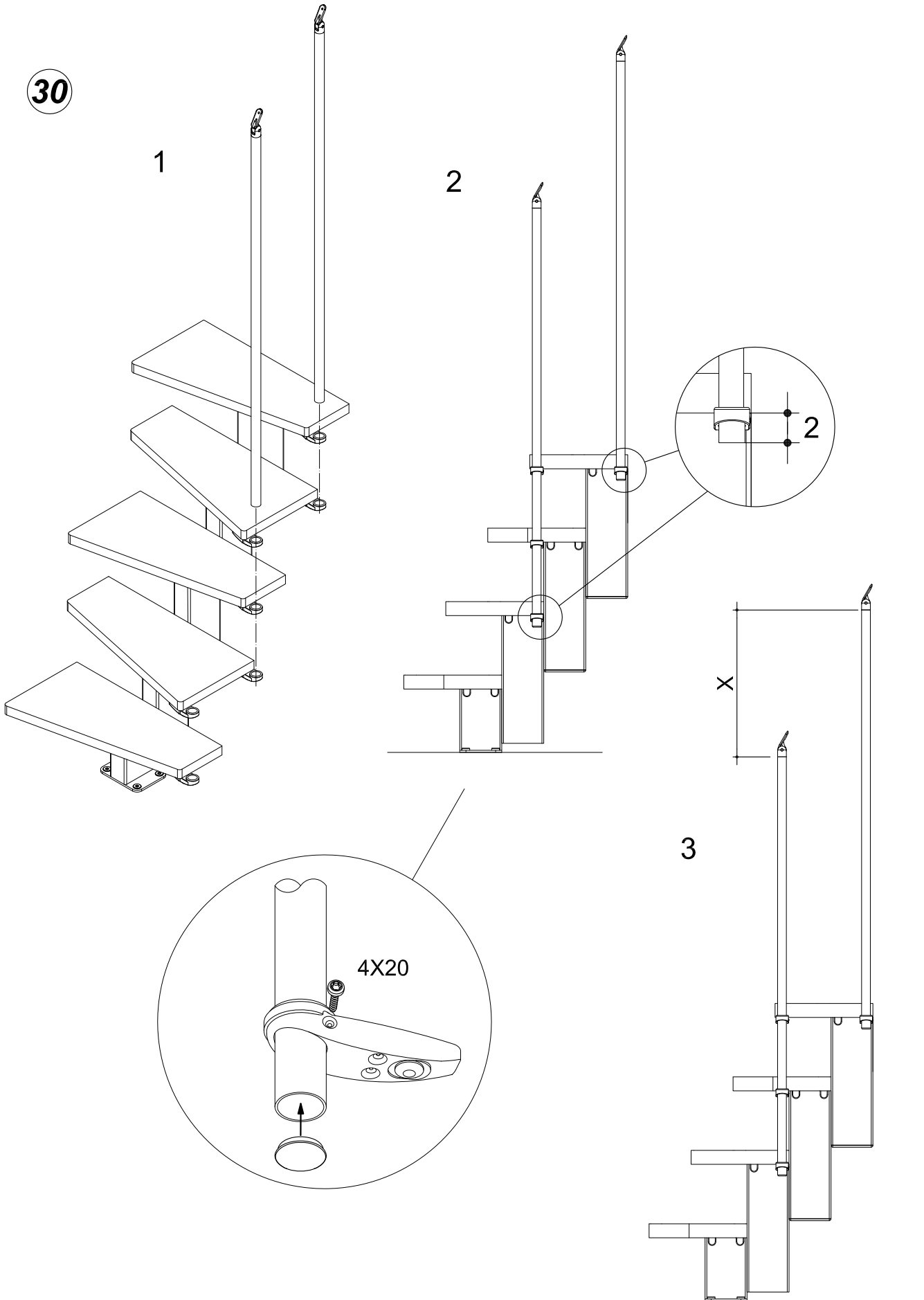

31

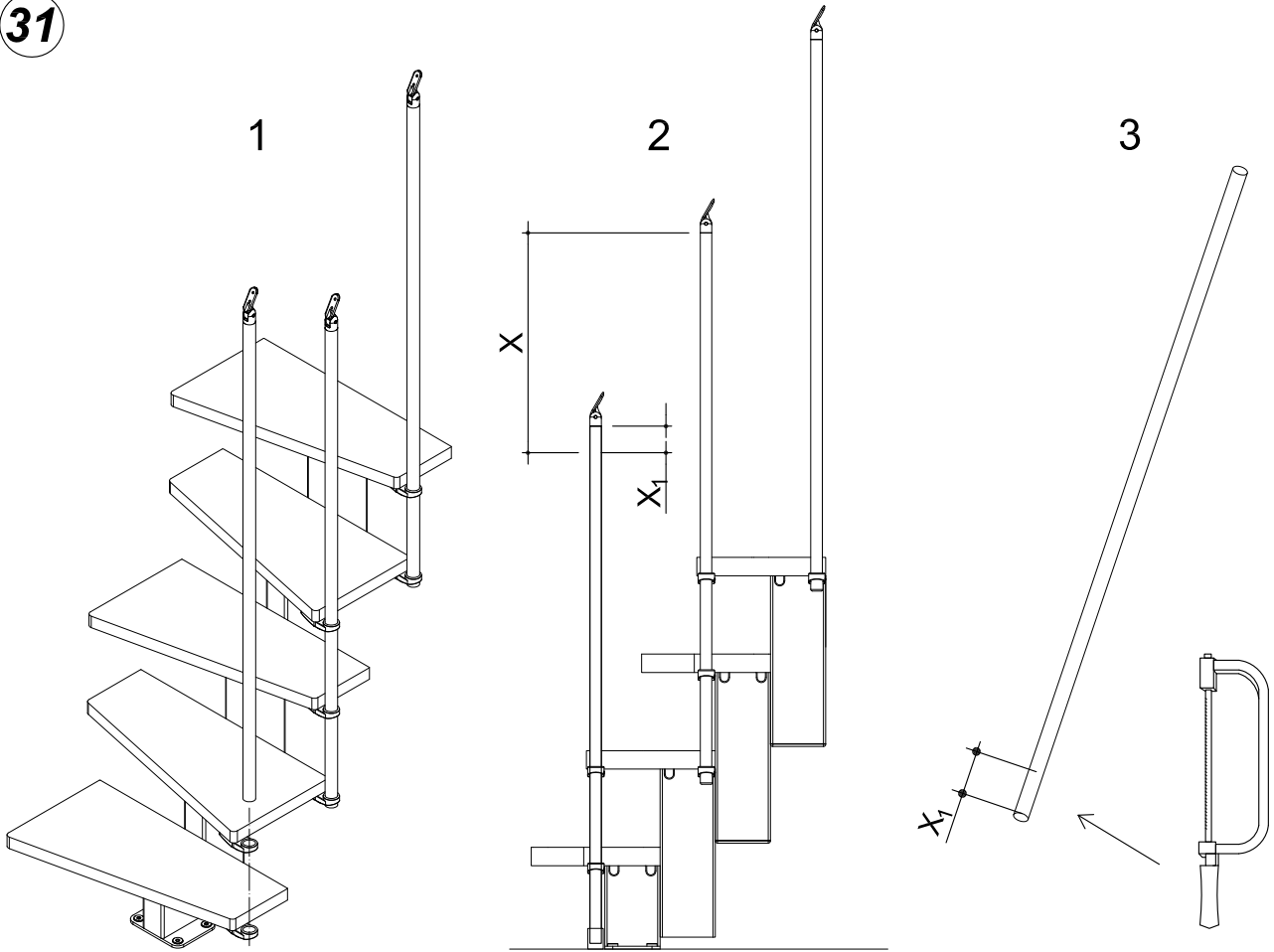

32

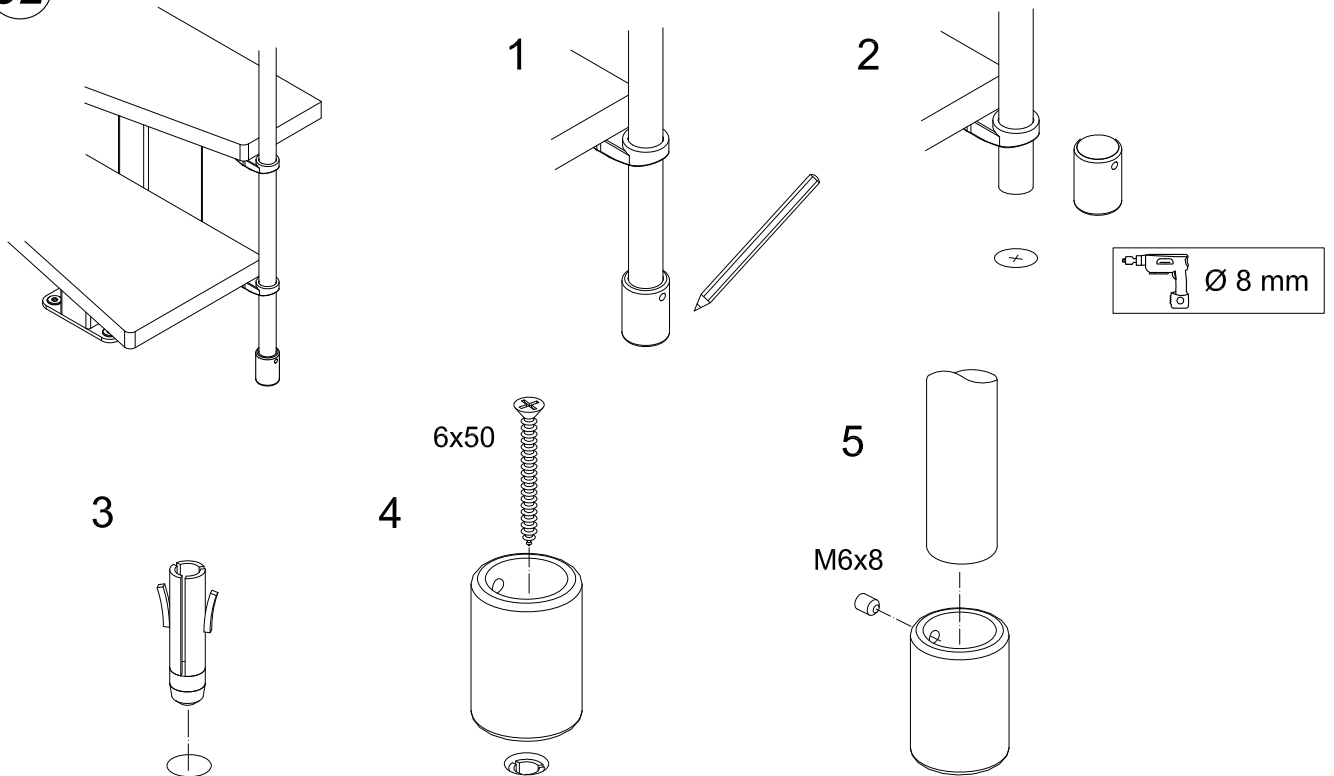

ASSEMBLAGGIO COLONNE: colonne intermedie / COLUMN ASSEMBLY: intermediate columns / MONTAJE COLUMNAS: columnas intermedias / ASSEMBLAGE DE COLONNES: colonnes intermédiaires / GELÄNDERSÄULEN-MONTAGE: Von den Zwischensäulen

33

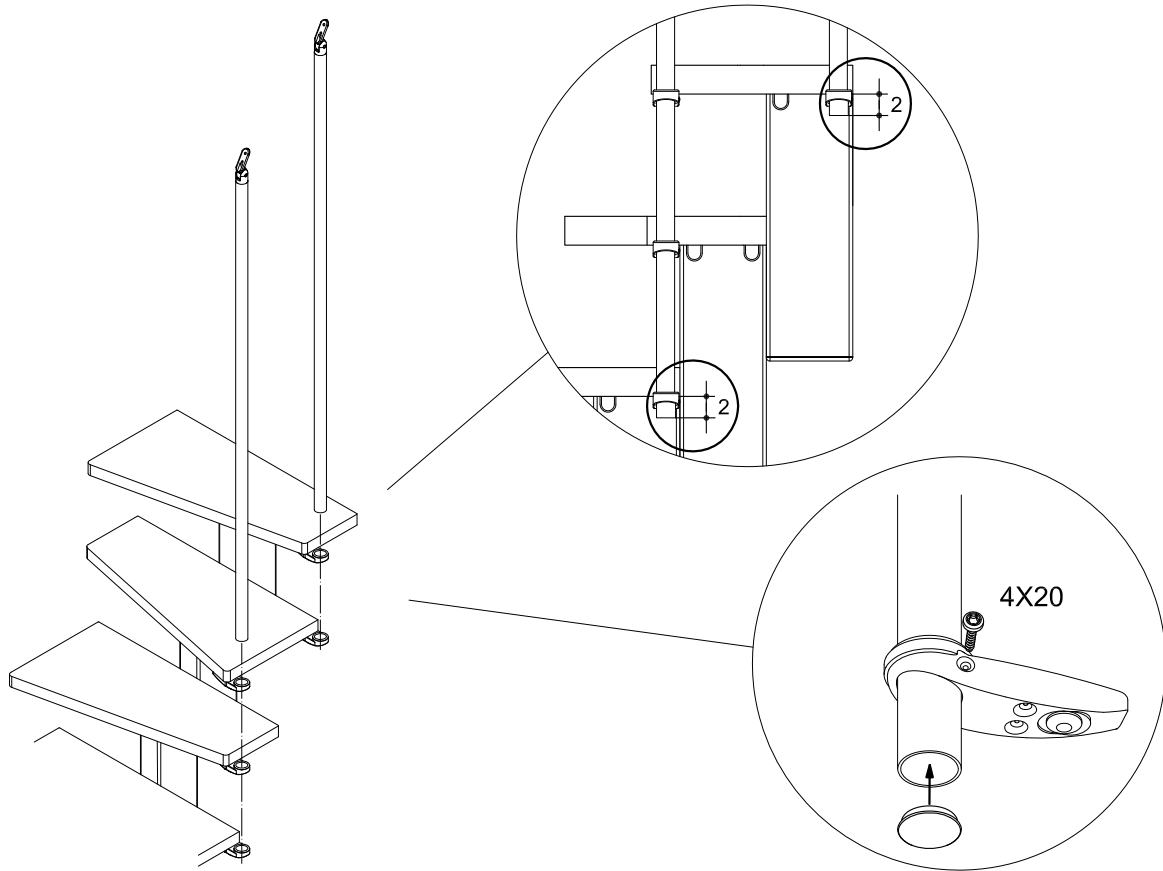

ASSEMBLAGGIO COLONNE: colonna finale / COLUMN ASSEMBLY: final column / MONTAJE COLUMNAS: columna final / ASSEMBLAGE DE COLONNES: dernière colonne / GELÄNDERSÄULEN-MONTAGE: Von der Endsäule

34

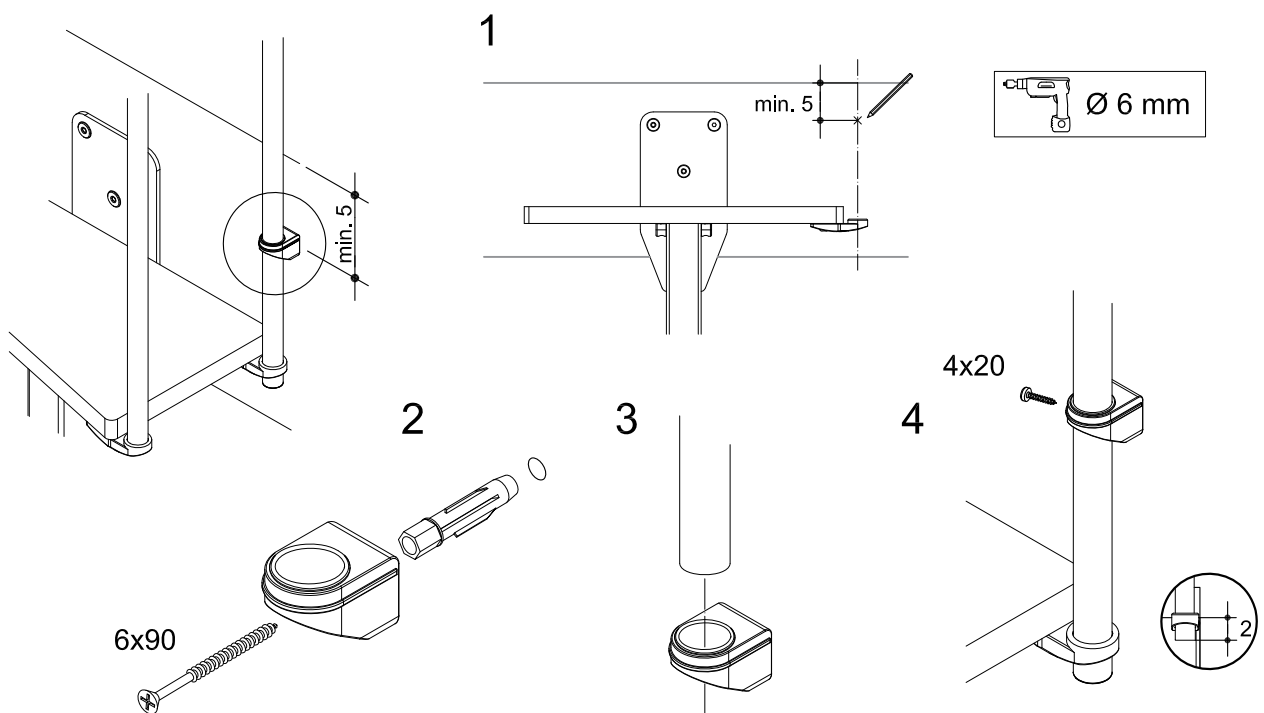

35

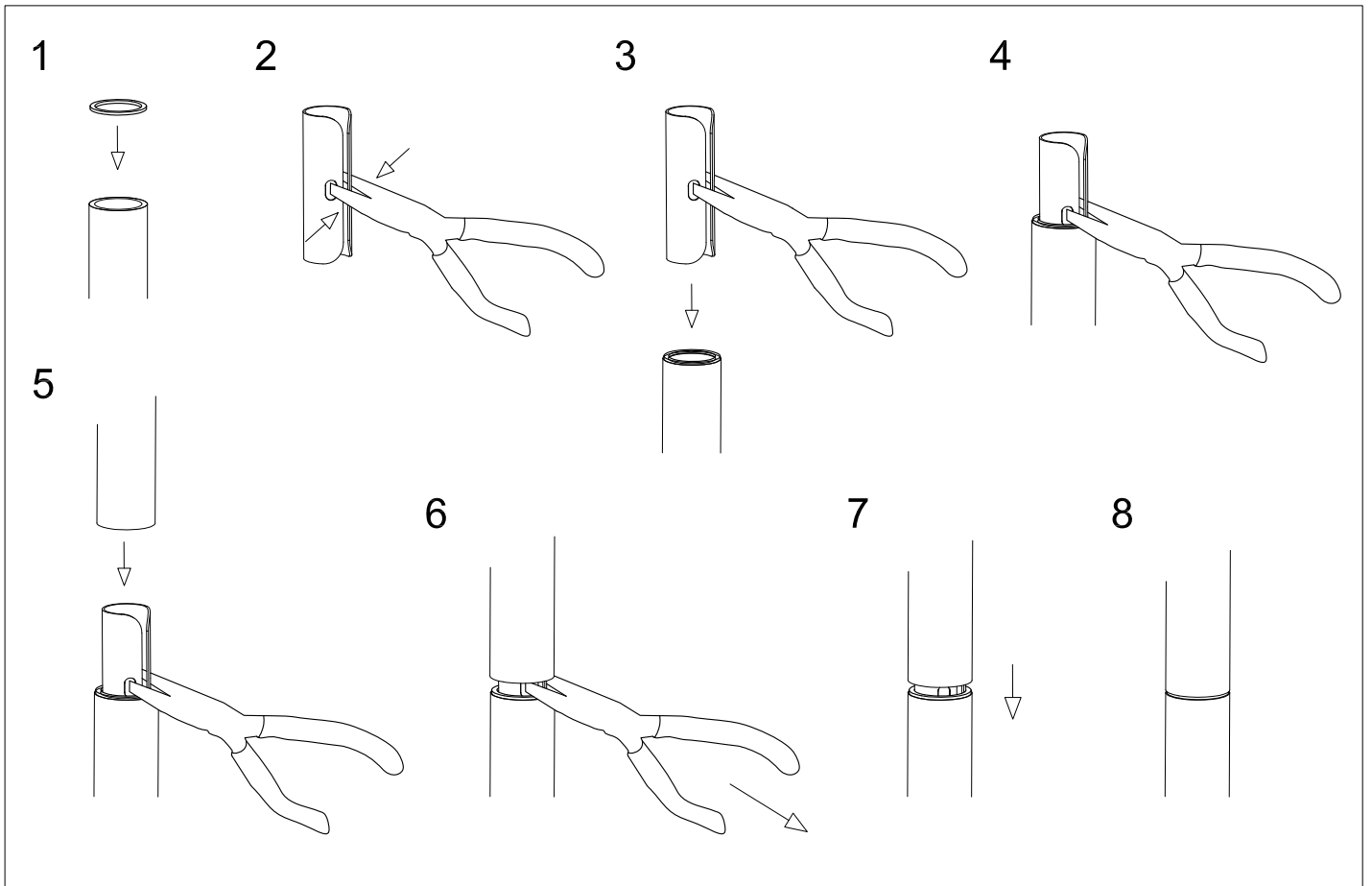
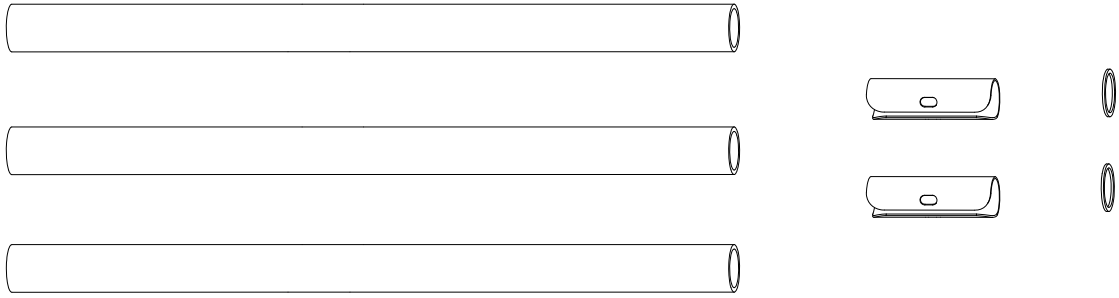

x 2

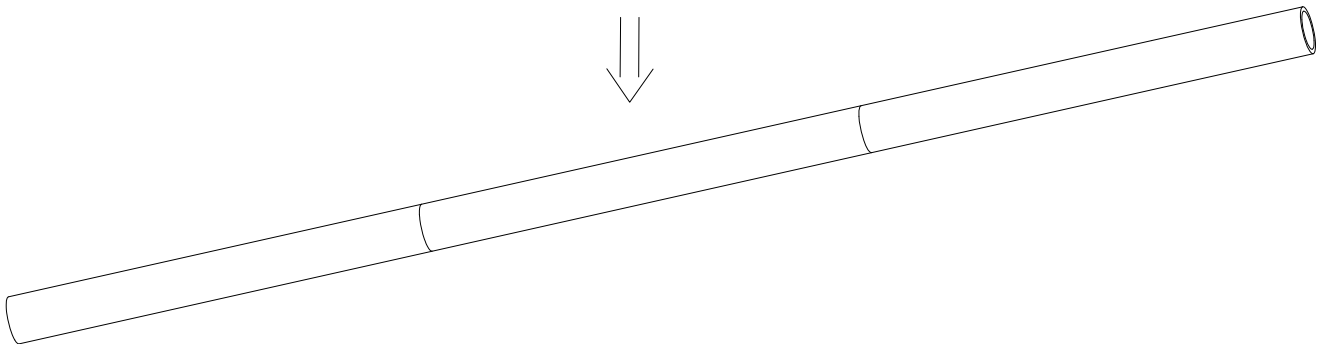

36

